

NATIONAL BOARD#: 11182

MODEL: FT-0400-C

C-Model Thermal Fluid Heater

Fulton's vertical coil design thermal fluid (hot oil) heater offers a compact, fuel-fired 4-pass heater design capable of operating temperatures to 750°F (400°C) with heater sizes from 800,000 BTU/hr to 14,000,000 BTU/hr output. The heater is designed to allow for high fluid velocities and low film temperatures, which translates into system longevity. The C-model heater can be incorporated into packaged systems to provide optimal operating efficiency and reliability.

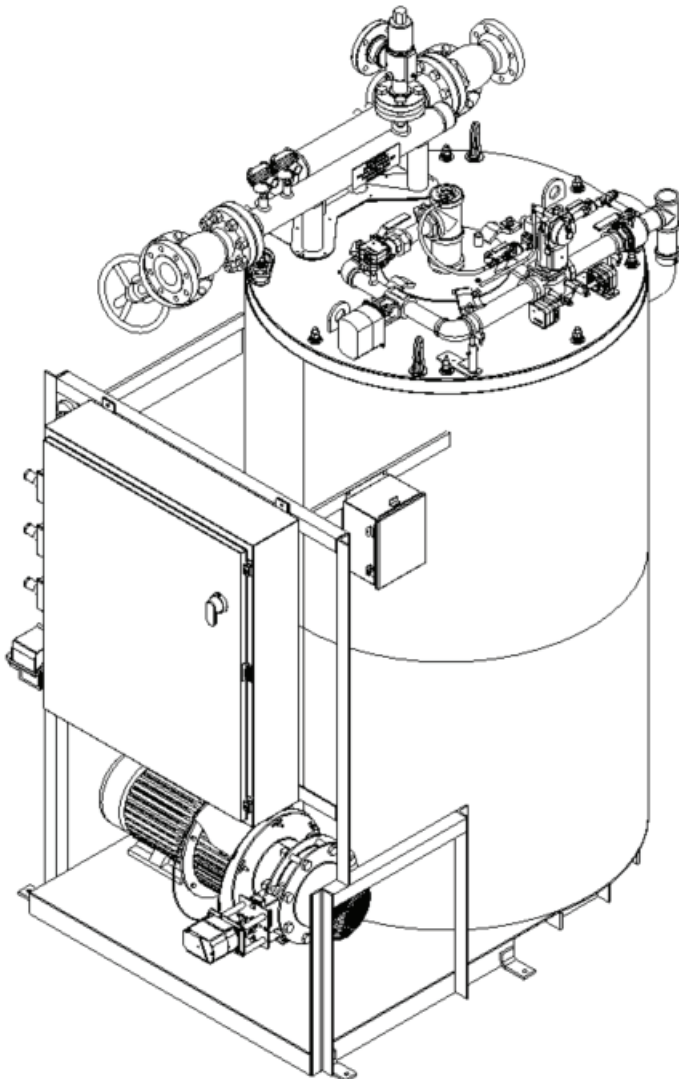

| | |
|-----------------------------|---|
| Model: | FT-0400-C |
| ASME Certifications: | ASME Section VIII 150 PSI MAWP 100 PSI Trim |
| Enclosure: | NEMA 4 |
| Fuel: | Natural Gas |
| Max. Operating Temp: | 650°F |

MAJOR CUSTOMER CONNECTIONS

| | |
|--------------------------------|---|
| Electrical: | 460/60/3, 40A |
| Thermal Fluid Supply: | 3" CL300 flanged connection |
| Thermal Fluid Return: | 3" CL300 flanged connection |
| Natural Gas: | 2" NPT connection, ½ psi supply pressure |
| SRV Discharge (Heater): | 2½" 150CL flanged connection |
| Flue: | 18" |

HEATER WEIGHTS & DIMENSIONS

| | |
|------------------------------|------------------------|
| Dry Weight: | 5,300 lbs |
| Thermal Fluid Volume: | 78 gallons |
| Heater Dimensions: | 64"L x 87"W x 115"H |

Equipment available for sale or for rent.