



# FBE

## High Efficiency Electric Steam Boiler

12 – 180 kW



- ▶ **Nearly 100% Efficient**
- ▶ **Zero Emissions**
- ▶ **Compact Design**

The FBE is a compact and reliable electric steam boiler capable of producing high-quality saturated steam with nearly 100% efficiency. The FBE is a clean-running, combustion-free boiler featuring a design pressure of 100 PSI and ASME-M certification.

# SPECIFICATIONS & DIMENSIONS

MODEL FB:	012E	018E	024E	030E	036E	048E	060E	072E	084E	108E	144E	157E	180E	
<b>SPECIFICATIONS</b>														
Boiler Output	BTU/HR	40,840	61,259	82,014	102,434	122,853	163,693	204,867	245,707	286,546	368,560	491,413	537,609	614,266
Steam Output	LBS/HR	42	63	84	106	127	169	211	253	295	380	506	554	633
<b>WEIGHTS</b>														
Shipping Weight	LBS	225	225	360	360	360	360	360	360	700	700	761	761	761
Operating Weight	LBS	184	184	337	337	337	431	431	431	573	573	837	837	837
Flooded Weight	LBS	201	201	381	381	381	475	475	475	656	656	949	949	949
<b>DIMENSIONS</b>														
(A) Width	IN	20.9	20.9	25.875	25.875	25.875	25.875	25.875	25.875	28.25	28.25	30.375	30.375	30.375
(B) Height	IN	36.7	36.7	45.875	45.875	45.875	45.875	45.875	45.875	60.3	60.3	59.875	59.875	59.875
(C) Depth	IN	31.375	31.375	32.5	32.5	32.5	32.125	32.125	32.125	33.3	33.3	35.375	35.375	35.375

**NOTE:** Specifications and dimensions are approximate and for reference only. Fulton practices continuous product improvement and reserves the right to change specifications and/or dimensions without notice.

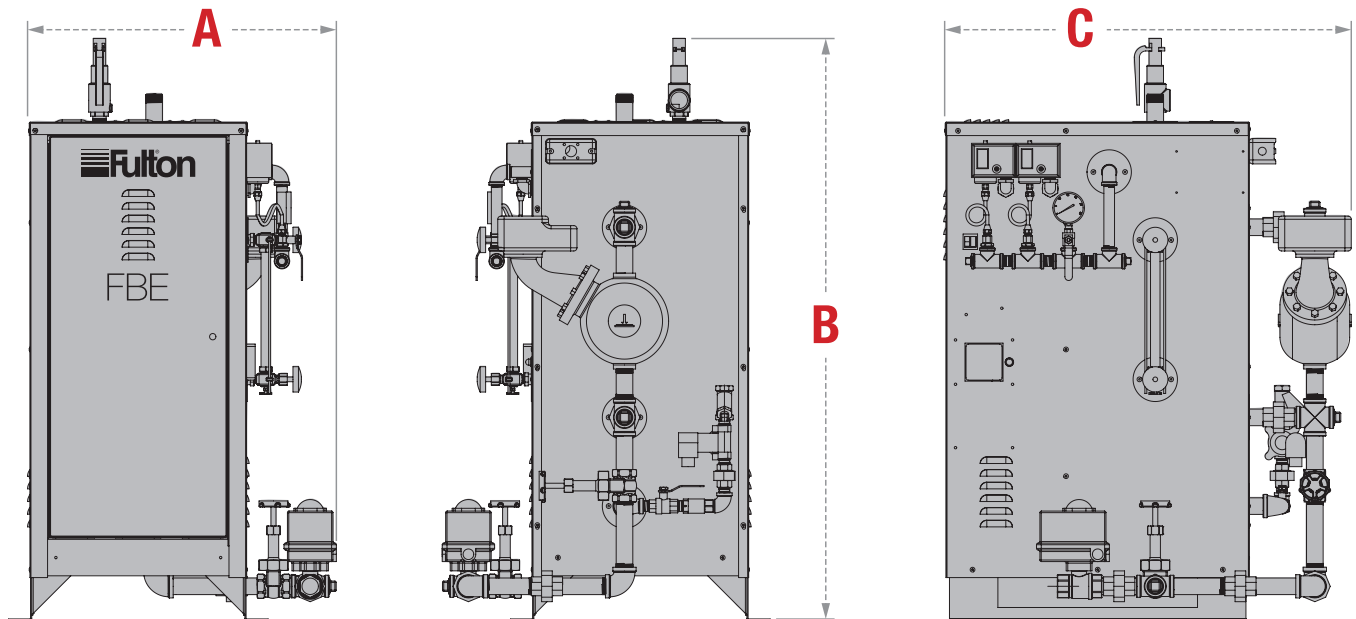

Call: (315) 298-5121

972 Centerville Road  
Pulaski, NY 13142



[fulton.com/fbe](http://fulton.com/fbe)

Drawings & documentation available online

FBE\_BROCHURE\_250617

