



INSTALLATION, OPERATION AND MAINTENANCE MANUAL

Endura XE (EXE)
Condensing Hydronic Boilers
399,000 - 750,000 BTU/HR
Featuring PURE Control®



Serial/ National Board Number _____

Model _____

Fulton Order _____

Owner _____

Site Name _____

Date _____

DIGITAL MANUAL:



Scan to download the latest digital copy of this manual



EXE-399-750-IOM-250730

THIS PAGE LEFT INTENTIONALLY BLANK

Introduction	1-1	Commission The Boiler.....	3-3
Overview	1-2	SYSTEM DESIGN AND BOILER OPERATION	3-3
Warnings & Cautions.....	1-2	Adjusting and Verifying Combustion	3-4
Regulatory and Standards Conformity	1-2	PREPARATIONS BEFORE SETTING COMBUSTION	3-4
Technology Terminology	1-3	LIGHTING THE BURNER AND STEPPING TO P10	3-5
		SETTING THE COMBUSTION CURVE	3-6
		VERIFYING SAFETIES AND IGNITION RELIABILITY	3-7
		UPON SUCCESSFUL COMPLETION.....	3-8
Installation	2-1	Combustion Parameters.....	3-9
Product Overview.....	2-2	Using the PURE Control® Interface	3-10
Placement & Rigging	2-3	NAVIGATION.....	3-10
Clearances and Serviceability	2-5	PURE Control® Menu Screens	3-11
Install Boiler Trim	2-5	BOILER	3-11
Install Water Piping	2-6	ALARM HISTORY	3-11
VARIABLE PRIMARY PIPING ARRANGEMENT	2-7	CIRCULATION	3-11
PRIMARY-SECONDARY PIPING ARRANGEMENT	2-10	LEAD/LAG.....	3-12
Meet Water Chemistry Requirements.....	2-11	PID	3-13
PREVENT OXYGEN CONTAMINATION	2-12	TEMPERATURE.....	3-14
ELIMINATE SYSTEM AIR	2-12	CONFIGURATION	3-15
Fill the Boiler With Water	2-12	Testing Safety Devices.....	3-16
Gas Supply Piping	2-12	PERFORM TEST OF LIMIT CONTROLS	3-16
INLET GAS PRESSURE	2-12	PERFORM TEST OF LOW GAS PRESSURE SWITCH	3-16
GAS PIPING INSTALLATION	2-14	PERFORM TEST OF HIGH GAS PRESSURE SWITCH	3-16
COMPONENTS REQUIRING VENTILATION TO THE OUTDOORS	2-14	PERFORM TEST OF LOW WATER CUT OFF	3-16
Install Condensate Drain Trap.....	2-16	PERFORM TEST OF MANIFOLD AIR SWITCH	3-16
Install pH Neutralizer	2-17		
Venting Requirements	2-18	Maintenance	4-1
Combustion Air Intake	2-19	General.....	4-2
COMBUSTION AIR SUPPLY FROM THE BOILER ROOM.....	2-20	Tool List	4-3
COMBUSTION AIR DUCTED FROM THE OUTDOORS.....	2-21	Daily Inspection Schedule	4-4
Flue Gas Exhaust Venting	2-22	Weekly Inspection Schedule	4-4
Common Flue Gas Venting Layouts.....	2-25	Monthly Inspection Schedule	4-4
COMMON VENTING EXHAUST BACKFLOW PREVENTION.....	2-26	Replacing or Updating the Boiler Control	4-4
Venting Terminations	2-26	Annual Maintenance Schedule.....	4-5
WALL THIMBLE INSTALLATION	2-27	Removing and Cleaning Burner Assembly	4-6
ROOF VENT TERMINATION.....	2-27	Removing and Cleaning Flame Rod.....	4-7
SIDE WALL VENT TERMINATION.....	2-27	Servicing the Direct Spark Ignition Electrode	4-8
Removing an Existing Boiler	2-31	After All Repairs and Maintenance	4-9
Assembly of Fulton Multi-Skid Systems.....	2-31	Parts Diagrams.....	4-9
Electrical Connections and Devices	2-32	Troubleshooting	4-15
LOCATIONS FOR FIELD WIRING	2-37		
ELECTRICAL AND CONTROLS OPTIONS.....	2-37	Service	5-1
		Pre-Commissioning Installation Checklist	5-3
Operation	3-1	Installation & Operation "Start-Up" Report	5-5
Perform Pre-Start-Up Inspection.....	3-2	Annual Maintenance Checklists	5-7
Fill and Purge the System.....	3-2	Notes	5-17

THIS PAGE LEFT INTENTIONALLY BLANK

INTRODUCTION

1

INSTALLATION

2

OPERATION

3

MAINTENANCE

4

SERVICE DOCUMENTS

5

Overview

Prior to shipment, the following inspections and tests are completed to ensure the highest standards of quality:

- Material inspections
- Manufacturing process inspections
- American Society of Mechanical Engineers (ASME) welding and hydrostatic test inspection
- Gas train leak test
- Hipot test and electrical inspection
- Test fire operating and safety tests
- Final inspection
- Crating inspection

This Installation, Operation and Maintenance Manual is provided as a guide to the correct operation and maintenance of your Fulton equipment, and should be read in its entirety and be made permanently available to the personnel responsible for the operation of the boiler. It should not, however, be considered as a complete code of practice, nor should it replace existing codes or standards which may be applicable. Fulton reserves the right to change any part of this manual without notice.

Installation, start-up, and maintenance of this equipment can be hazardous and requires trained, qualified installers and service personnel. **Trained personnel are responsible for the installation, operation, and maintenance of this product, and for the safety assurance of installation, operation, and maintenance processes. Do not install, operate, service or repair any component of this equipment unless you are qualified and fully understand all requirements and procedures. Trained personnel refers to those who have successfully completed Fulton Service School training specific to this product.**

Installers, technicians, and operating personnel must, at all times, observe all warnings, cautions, and notes in literature, on stickers and labels, and any additional safety precautions that apply. Follow all safety codes and wear appropriate safety protection. Follow all jurisdictional codes and consult any jurisdictional authorities prior to installation.

Warnings & Cautions

WARNINGS and CAUTIONS appear in various chapters of this manual. It is critical that all personnel read and adhere to all information contained in WARNINGS and CAUTIONS.

- WARNINGS must be observed to prevent serious injury or death to personnel.
- CAUTIONS must be observed to prevent damage or destruction of equipment or loss of operating effectiveness.

All Warnings and Cautions are for reference and guidance purposes, and do not substitute for required professional training, conduct, and strict adherence to applicable jurisdictional/professional codes or regulations.

Regulatory and Standards Conformity

Installation of the equipment shall conform to all the requirements or all national, state and local codes established by the Authorities Having Jurisdiction (AHJ) or, in the absence of such requirements, in the US to the National Fuel Gas Code ANSI Z223.1/NFPA 54 latest edition, the National Electric Code (NEC) NFPA 70 latest edition, and the requirements in this manual. The AHJ should be consulted prior to installation.

When required by local codes, the installation must conform to the American Society of Mechanical Engineers Safety Code for Controls and Safety Devices for Automatically Fired Boilers (ASME CSD-1). The controls and safety devices of this boiler meet the requirements set forth in the ASME CSD-1 standard. The Manual Reset High Limit (MRHL) provided with this boiler is listed to UL 353 per ASME CSD-1 requirements.

AXA XL requires compliance with ASME CSD-1 up to 12,500,000 BTU/hr. XL Catlin, GE GAP, and IRI have been replaced by AXA XL.

FM Global follows ASME CSD-1 requirements. FM Global will accept any UL or ETL listed and labeled packaged boiler up to and including 2,500,000 BTU/hr without requiring FM Global approved components. FM Global requires boilers with capacities above 2,500,000 BTU/hr and up to 12,500,000 BTU/hr use FM Global approved components when applicable and available.

The boiler pressure vessel is manufactured and stamped in accordance with ASME Boiler and Pressure Vessel Code, Section IV for a maximum allowable working pressure and operating temperature of 160 psig and 210°F (99°C) respectively.

Input ratings and efficiency have been certified by AHRI based on standard test procedures prescribed by the United States Department of Energy.

Technology Terminology

Term	Definition
AFS	Air Filter Switch
AHJ	Authority (Authorities) Having Jurisdiction
ALM	Accurate Lambda Meter, a wideband O2 sensor controller
ANSI	American National Standards Institute, an organization that oversees the development of voluntary consensus standards in the United States
AC	Alternating Current
AS	Air Switch
ASME	American Society of Mechanical Engineers, an organization that sets internationally recognized industrial and manufacturing codes and standards that enhance public safety
Automatic Reset	A burner lockout condition that clears itself and restores operation automatically after the condition resolves. The alarm history annunciation associated with an automatic reset may be referred to as a warning, error, advisory, alert, event, log or fault.
BAC	BACnet building integration protocol
BAS, BMS	Building Automation Systems, also known as BMS, Building Management System
BTU	British Thermal Unit
BTU/HR	BTU per Hour, 1 BTU/hr = 0.29 W
CFH, SCFH	Cubic Feet Per Hour, Standard Cubic Feet Per Hour, 1 CFH = 0.028 m3/hr
CSR	Condensate Safety Relay
DC	Direct Current
DHW	Domestic Hot Water
DMM	Digital Multimeter
ECM	Electronically Commutated Motor
E-Stop	Emergency Stop
Ethernet	A wired networking technology that enables devices to communicate efficiently, commonly used in local and wide-area networks.
Firmware	Low-level software that provides essential instructions for hardware and bridges hardware with higher-level software
Flame-by-Wire	A system which replaces conventional combustion controls with electronic signals to actuators
GND	Ground
GUI	Graphical User Interface
HGP(S)	High Gas Pressure (Switch)
HMI	Human Machine Interface, the hardware and software components for operator interaction
Hydronic	A comfort heating or cooling system that uses water or glycol blends as the heat transfer medium
ID (I.D.)	Inside Diameter
ILK	Interlock
IOM	Installation, Operation and Maintenance Manual
IT	Ignition Transformer
LCI	Limit Control Input on the flame safeguard
LGP(S)	Low Gas Pressure (Switch)
LMV	Siemens Burner Management (Flame Safeguard) Control

Term	Definition
LWCP	Low Water Cut-off Probe
LWSR	Low Water Safety Relay
Manometer	A tool used to measure the pressure of gases or liquids, typically a U-shaped tube filled with liquid to indicate pressure differences
Manual Reset	A burner lockout condition that requires human intervention to resolve the condition and restore operation. The alarm history annunciation associated with a manual reset may be referred to as a manual lockout, alarm, error, fault, trip, failure, or shutdown.
MBH	1,000 BTU per Hour
MMBH	1,000,000 BTU per Hour
Modbus	A communication protocol for industrial automation that allows devices to communicate over a network
MRHL, HLTC	Manual Reset High Limit, also referred to as High Limit Temperature Control
MV	Main gas valve
MV Downstream	Main gas valve downstream setpoint gas pressure
NC (N.C.)	Normally Closed
NFPA	National Fire Protection Association
NO (N.O.)	Normally Open
NOx	Nitrogen oxides, primarily nitric oxide (NO) and nitrogen dioxide (NO ₂), produced during combustion processes
NPT	National Pipe Thread
NTC	10k Ohm Thermistor, a type of temperature sensor
O2	Oxygen, typically used in the context of excess Oxygen in the combustion flue gases
OAT	Outdoor Air Temperature
OCI	Operator Control Interface
OD (O.D.)	Outside Diameter
OTC	Operating Temperature Control
PN, P/N	Part Number
PB	Push Button
PCB	Printed Circuit Board
PID	Proportional, Integral, Derivative
PLC	Programmable Logic Controller
POC	Proof of Closure
PPM	Parts per Million
Primary Pump	A dedicated boiler circulator pump used in primary-secondary piping arrangements
Process Variable	The real-time value measured from the system, such as temperature or pressure, which the PID controller continuously monitors to maintain the process
PS, PSU	DC Power Supply (Unit)
PSI	Pounds per Square Inch
PURE Control	Fulton's integrated boiler control system that optimizes temperature control and lead/lag functionality, manages internal boiler systems, and integrates with automation systems
PWM	Pulse Width Modulation
QRA	An Ultra Violet Flame Scanner
RS-485	A serial communication standard that enables communication between multiple devices

Term	Definition
RTD	Resistance Temperature Detectors, a type of temperature sensor
SAS	An actuator used for automatic gas pressure setpoint adjustment of the SKP regulator
Secondary Pump	The pump(s) used to circulate flow through the building system loop, in variable primary arrangements secondary pump(s) also circulate flow through the boilers
Setpoint	The desired temperature or pressure target value that the PID controller adjusts system inputs in order to reach and maintain
SKP	An electro-hydraulic gas safety shut off actuator
SIB	Signal Interface Board
SM	Servo Motor or Stepper Motor, used for various motion control functions
Software	High level user-interaction application
SOLA	Honeywell or Resideo Flame Safeguard Control
VAC	Volts Alternating Current
VDC	Volts Direct Current
VFD, VSD	Variable Frequency Drive or Variable Speed Drive, used to control the speed of an AC motor
W	Watts
W.C.	Water Column, used as a measurement of pressure as Inches of Water Column, "W.C.
XF	AC Power Transformer

- NOTE: The terms listed are for reference purposes only and do not necessarily represent items that are included with the boiler or supplied as standard equipment.

PAGE INTENTIONALLY LEFT BLANK

INTRODUCTION

1

INSTALLATION

2

OPERATION

3

MAINTENANCE

4

SERVICE DOCUMENTS

5

WARNING

All information in this manual is for reference and guidance purposes, and does not substitute for required professional training, conduct, and strict adherence to applicable jurisdictional/professional codes and regulations.

CAUTION

The standard configuration for this boiler is certified for indoor installation only.

This hydronic heating boiler is not suitable for use as a domestic water heater. Do not heat potable water, such as used for showers, sinks, dishwashers, or washdown process directly through the boiler.

This boiler is not designed for use in systems where water is continuously replenished. The warranty is valid for closed loop systems only.

Fulton cannot be held responsible for the selection, engineering, installation, or sizing of any additional equipment or components of the hydronic heating system.

Product Overview

Prior to the performance of installation, operation, or maintenance procedures, personnel should become familiar with the equipment (**Table 1** and **Figure 1**) and its components.

The Fulton Endura XE hot water boiler is an automatic, fuel-fired, ultra high-efficiency boiler. Combustion air supply may be ducted to the boiler from the outdoors or utilize conventional methods.

The boiler is capable of sidewall venting when the appropriate venting materials are used, and when permitted by local code requirements.

This boiler is ETL listed and labeled to ANSI Z21.13-2017/CSA 4.9-2017 standard for Gas-fired low pressure steam and hot water boilers for indoor installation. The boiler heat exchanger is manufactured and bears the "H" stamp in accordance with American Society of Mechanical Engineers (ASME) Boiler and Pressure Vessel Code, Section IV for a maximum allowable working pressure and temperature of 160 psi and 210° F (99° C) respectively. It is hydrostatically tested, test fired and shipped as a complete packaged unit.

Fuel, water and electrical connections are similar to other boilers of this type.

This boiler is to be installed as part of a hydronic heating system. A qualified engineer must be consulted for the selection of the equipment and components of the heating system. Improper system conditions can result in incorrect heat distribution to users of the heating system.

Each boiler is supplied with the following:

- Integrated combustion supervision and temperature operating control
- Operating and high temperature probe(s) in pressure vessel
- Low water probe(s) in pressure vessel
- ASME safety relief valve and tee
- Installation, Operation, and Maintenance Manual
- Test fire report
- Wiring diagram
- Temperature and pressure (T&P) gauge

The customer should examine the equipment for any damage. It is the responsibility of the installer to ensure all parts supplied with the equipment are fitted in a correct and safe manner.

Placement & Rigging

Proper placement of your Fulton product is essential. Attention paid to the following points will save a great deal of difficulty in the future. Correct placement is the first step to trouble-free installation, operation, and maintenance.

Adhere to the following for placement and rigging:

1. Check building specifications for permissible floor loading. Use **Table 1** for unit reference.
2. Conform to all the requirements of all national, state and local codes established by the authorities having jurisdiction and/or the U.S. to the National Fuel Gas Code, latest edition. Authorities having jurisdiction should be consulted before installations are made. Where required by local codes, the installation must conform to American Society of Mechanical Engineers Safety Code for Controls and Safety Devices for Automatically Fired Boilers (ASME CSD-1).
3. Since an external electrical source is utilized, the boiler, when installed, must be electrically ground in accordance with the National Electric Code, American National Standards Institute (ANSI) National Fire Protection Association (NFPA) 70, latest edition.
4. This boiler is designed for room temperatures above 32°F (0°C) and not exceeding 104°F (40°C).
5. Install so that all system components are protected from water (dripping, spraying, rain, etc.) and debris (dry wall dust, insulation particles, etc.) during boiler operation and service.
6. Install on a level, non-combustible surface only in the vertical position. Concrete is strongly recommended. Do not install the boiler on springs. Use shims if necessary to ensure boiler is level.
7. Provide combustion and ventilation air in accordance with applicable provisions of local building codes or: USA – NFPA 54/ANSI Z223.1, Section 5.3, Air for Combustion and Ventilation. This boiler supports configurations for either direct vent installation or for installation using indoor combustion air.
8. Locate the boiler so that the combustion air supply and exhaust piping between the boiler and outside wall/roof are within the maximum lengths for horizontal or vertical venting if sealed combustion will be used. See **Clearances and Serviceability section** of this manual.



WARNING

Competent personnel in accordance with all applicable local codes should carry out the installation of the Fulton equipment. All state and jurisdictional codes beyond the scope of the applicable ASME Boiler and Pressure Vessel Codes, for its corresponding classification, should be followed in all cases. Jurisdictional authorities must be consulted prior to installation.

A competent rigger experienced in handling heavy equipment should handle rigging your equipment into position.

The equipment must be installed on a non-combustible surface.

Failure to provide required and safe access to the equipment could impede commissioning and maintenance. Service technicians are instructed not to commence commissioning if hazardous conditions exist.

Failure to provide proper minimum clearances between equipment and combustible materials may result in fire.



CAUTION

Some soap used for leak testing is corrosive to certain types of metals. Clean all piping thoroughly after completing the leak check.

Do not allow weight to bear on equipment components to prevent damage.

Do not use to directly heat a swimming pool.

TABLE 1 - BOILER DIMENSIONS AND OPERATING SPECIFICATIONS⁷

Specifications	EXE	399	500	650	750
Rated Input Capacity ¹	MBH	399	500	650	750
Minimum Input at Low Fire	MBH	33	33	50	50
Output at AHRI-1500 conditions	MBH	391	487	626	720
Fuel Consumption at Capacity ²	SCFH	395	495	643	742
Nat. Gas Pressure Required ³	W.C.	3.5 - 14	3.5 - 14	3.5 - 14	3.5 - 14
Low Fire Variable Water Flow	GPM	4 - 105	4 - 105	4 - 125	4 - 125
High Fire Variable Water Flow	GPM	16 - 105	20 - 105	26 - 125	30 - 125
Minimum Circuit Ampacity ⁴ (120/1/60)	AMP	10	10	10	10
Full Load Amps ⁴ (120/1/60)	AMP	8	8	8	8
Dimensions	EXE	399	500	650	750
A. Boiler Width	IN	26.3	26.3	26.3	26.3
B. Boiler Height	IN	73.7	73.7	73.7	73.7
C. Boiler Skid Depth	IN	28.9	28.9	28.9	28.9
Connections	EXE	399	500	650	750
D. Flue Gas Vent ⁵ (dia)	IN	4	4	6	6
E. Combustion Air Inlet ⁵ (dia)	IN	4	4	6	6
F. Water Inlet (dia)	IN	2	2	2	2
G. Water Outlet (dia)	IN	2	2	2	2
H. Gas Inlet (dia)	IN	1	1	1	1
I. Condensate Drain (dia)	IN	0.75	0.75	0.75	0.75
Minimum Clearance	EXE	399	500	650	750
J. Front	IN	24	24	24	24
K. Rear ⁶	IN	12	12	12	12
L. Top	IN	16	16	16	16
M. Sides	IN	0	0	0	0

NOTES:

- 1) May be operated up to 10,000 feet elevation, and up to 1,000 feet elevation at 80° F without de-rate. Consult your Fulton Representative for capacities at higher elevation.
- 2) Applies to natural gas with a calorific value of 1,010 BTU per FT³.
- 3) Standard natural gas configurations only. Alternate or custom configurations may have different requirements; always review the boiler nameplate before installation.
- 4) Standard electrical configurations only. Alternate or custom configurations may have different requirements; always review the boiler nameplate before installation.
- 5) An appliance adapter may be required.
- 6) 12-inch rear clearance is to combustibles and for maintenance, allow for 24-inch rear clearance to accommodate installation of the flue gas exhaust vent.
- 7) Specifications and dimensions are approximate and for reference only. Fulton practices continuous product improvement and reserves the right to change specifications and/or dimensions without notice.

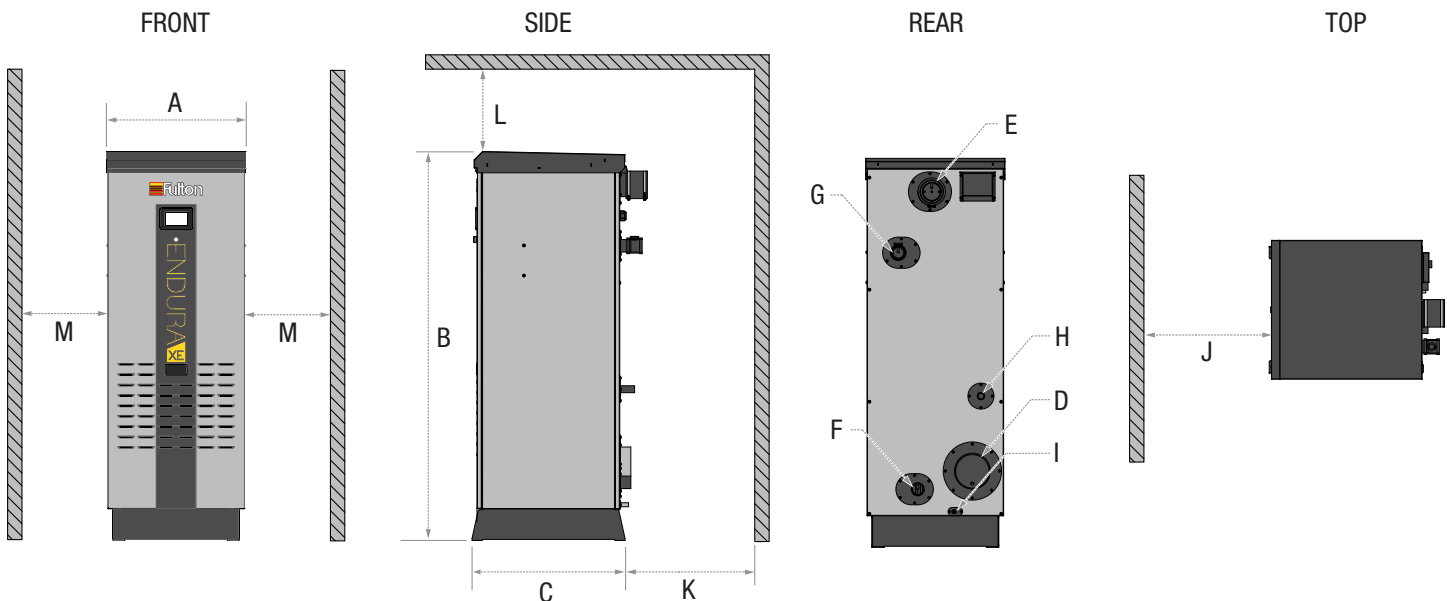

FIGURE 1 - DIMENSIONS AND CLEARANCES

Clearances and Serviceability

Adhere to the following for clearances and serviceability:

1. All local and national codes (NFPA, ANSI, UL, CSA, ASME) must be followed for proper clearances and serviceability of your boiler. Authorities having jurisdiction should be consulted before installations are made.
2. Appropriate front, back, side and top clearances must be maintained (**Figure 1**). This will allow equipment access to facilitate maintenance and a safe work environment. Side clearance is not necessary unless required by local code(s).
3. Although 12-inch rear clearance is permitted, some installations may require or benefit from 24-inch rear clearance.
4. Ensure the installation provides sufficient clearance and visibility for access to all labels, inspection points, the safety relief valve, and for maintenance.
5. Do not mount boiler room accessories or other components directly to the boiler cabinet frame or jacket panels as this may impede maintenance.

Install Boiler Trim

Each boiler is supplied with a safety relief valve sized in accordance with ASME Section IV requirements. Safety relief valve size is determined by trim pressure and is supplied in the trim kit. See **Table 2** for inlet and outlet sizes.

1. The safety relief valve (**Figure 2**) must:
 - » Be mounted to a tee located on the top of the boiler supply (outlet) piping.
 - » Be installed in the upright vertical position.
 - » Not be isolated from the boiler pressure vessel by any valves.
 - » Have a minimum relief valve capacity of 750 lbs. per hour.

2. The discharge pipe must:
 - » Not have a diameter less than the full area of the valve outlet.
 - » Be as short and straight as possible and so arranged as to avoid undue stress on the valve.
 - » Be supported by means other than the safety valve itself.
 - » Be piped to avoid danger of scalding personnel.

TABLE 2 - TYPICAL SAFETY RELIEF VALVE INLET AND OUTLET SIZES

Trim Pressure PSI (kPa)	Inlet Size inch (mm)	Outlet Size inch (mm)
30 (206.84)	1 (25.4)	1 1/4 (31.75)
60 (413.69)	3/4 (19.05)	1 (25.4)
100 (689.48)	3/4 (19.05)	1 (25.4)
125 (861.84)	3/4 (19.05)	1 (25.4)
160 (1103.16)	3/4 (19.05)	1 (25.4)

Each boiler is equipped with a pressure-temperature gauge to be installed in the outlet piping section of the boiler. The gauge must not be isolated from the boiler by any valve.

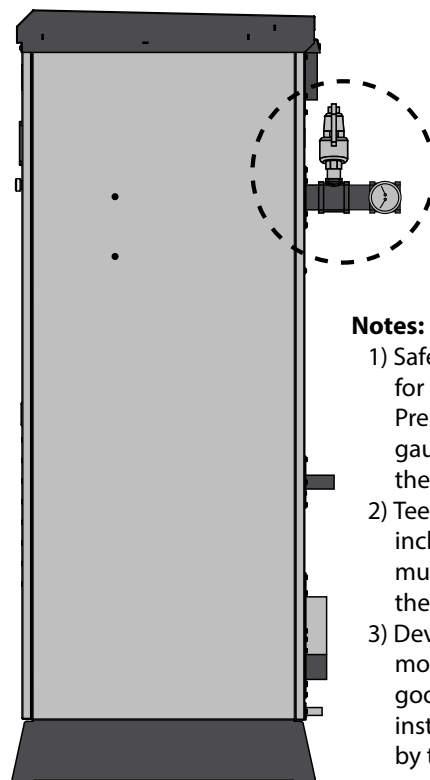

Notes:

- 1) Safety Relief Valve (SRV), tee for SRV, and combination Pressure & Temperature (P&T) gauge are shipped loose in the boiler trim kit.
- 2) Tee for P&T gauge is not included with the boiler, it must be provided by the installing contractor.
- 3) Devices shown must be mounted in accordance with good practices, these instructions and local code by the installing contractor.

FIGURE 2 - BOILER TRIM INSTALLATION LOCATION

WARNING

All information in this manual is for reference and guidance purposes, and does not substitute for required professional training, conduct, and strict adherence to applicable jurisdictional/professional codes and regulations.

The discharge from the safety relief valve must be arranged to ensure no danger of scalding personnel, or equipment damage.

Provisions must be made to properly pipe the safety relief discharge away from the boiler to the point of discharge.

No shutoff of any kind shall be placed between the safety relief valve and the boiler, or in the discharge pipe between the valve and the atmosphere. Doing so may cause an explosion from overpressure.

CAUTION

The hydronic system should never be flushed while the boiler is attached to the system since the debris could accumulate in the boiler and block water from passing through the heat exchanger.

This hydronic heating boiler is not suitable for use as a domestic water heater. Do not heat potable water, such as used for showers, sinks, dishwashers, or washdown process directly through the boiler.

Install Water Piping

All water supplies contain some solids, dissolved gases or dissolved minerals. These may cause corrosion, deposition and/or fouling of equipment. To prevent these contaminants from impacting boiler performance, valve operation and general pipe longevity, you must analyze and treat each installation uniquely.

Adhere to the following for water piping installation (see **Figures 4 – 7**):

- Manual isolation valves are recommended on both water connections for ease of service.
- Install piping so that the boiler is not supporting any piping load.
- Install manual purging valves in all loops and zones.
- Install a pressure-reducing (automatic fill) valve in the cold water fill line to the boiler system, and set to meet or exceed a minimum pressure of 12 psi at the boiler. For systems using up to 50% glycol, a minimum 30 psi fill pressure is required at the boiler outlet.
- To prevent scale and corrosion in boiler and associated piping, make up water must be kept to a minimum. This is best achieved by ensuring immediate repair of all leaks and maintaining system pressure.
- Check that the proposed operation of zone valves, zone circulator(s) and diverting valves will not isolate air separator(s) and/ or expansion tank(s) from the boiler.
- Provide at least 6 inches (152 mm) clearance from hot water pipes to combustibles.
- When used with a refrigeration system, install the boiler so that the chilled medium is piped in parallel with the boiler with appropriate valves to prevent the chilled medium from entering the boiler. If the boilers are connected to heating coils (located in air handling units) where they may be exposed to refrigerated air circulation, such boiler piping systems must be equipped with flow control valves or other automatic means to prevent gravity circulation of the boiler water during the cooling cycle.
- Include the following in the mechanical equipment in the hydronic heating system:
 - » *An automatic pressure activated water make up valve with back flow preventer. It must be set to maintain required Net Positive Suction Head (NPSH) for re-circulating pumps, a positive system pressure at the highest point of at least 5-10 PSIG, and should be designed to add water to the system at the outlet of the boiler but should not be fed directly into the boiler.*
 - » *Air removal equipment, including an air separator and automatic breather valves, along with a functioning expansion tank. Each must be designed to system specifications.*
- A drain valve is recommended (not provided) on the boiler inlet piping.
- Boiler connection dimensions are for reference and not for construction purposes. Pre-fabricating boiler piping is not recommended.

- Install filtration in the common loop or per boiler to remove particulates if appropriate. A #4 or finer mesh size is required.
- Install bypass chemical feeder for corrosion inhibitor maintenance if appropriate.
- Install corrosion coupon holder to assess corrosion inhibitor performance if appropriate.
- Before installing the boiler into a hydronic loop, be sure that the system piping and any other components of the system are clean and free of debris and any foreign matter. The hydronic system must be completely flushed prior to installing the boiler.

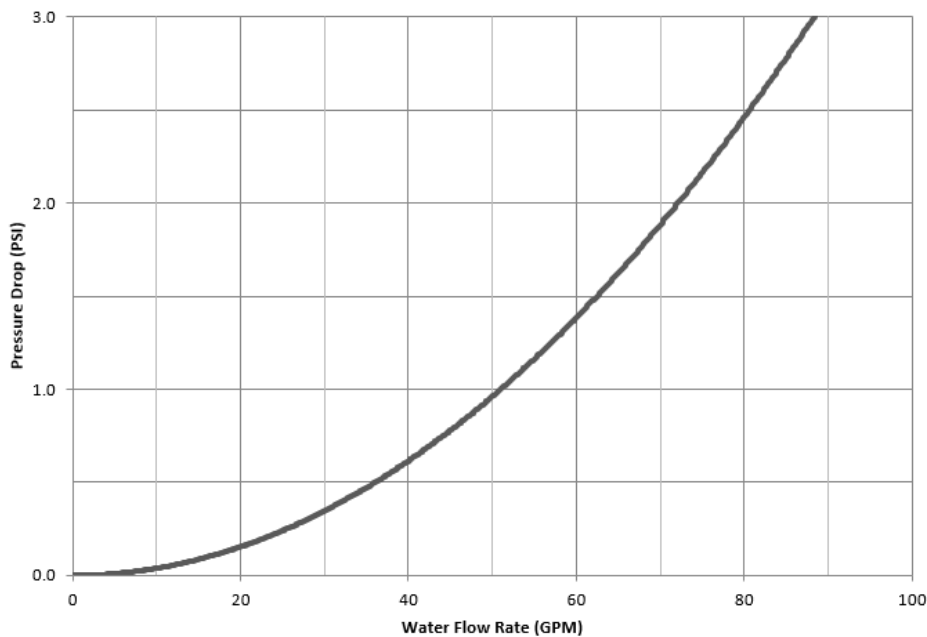

FIGURE 3 - TYPICAL WATER SIDE PRESSURE DROP

■ Variable Primary Piping Arrangement

This boiler is designed for installation in variable primary flow piping arrangements (see **Figures 4** and **5**), sometimes referred to as full flow systems. This arrangement eliminates temperature mixing associated with primary-secondary piping, thereby delivering the lowest temperature water directly to the boiler return connections and increasing thermal efficiency of the condensing boiler plant.

Adhere to the following for variable primary piping arrangements:

- Select secondary (system) pump(s) with sufficient total dynamic head for the pressure drop of the loop at design flow. See **Figure 3** for the boiler water pressure drop. This boiler will automatically perform a safe shutdown in the event of a low flow condition; however, proper design flow is required to deliver heat to the users and prevent nuisance lockouts.
- Install a motorized isolation valve per boiler. This eliminates flow through idle boilers in accordance with ASHRAE 90.1-2013 (6.5.4.3.2). Blending of unheated supply water impacts temperature control operation and can cause manual reset high temperature lockouts.

⚠ WARNING

All information in this manual is for reference and guidance purposes, and does not substitute for required professional training, conduct, and strict adherence to applicable jurisdictional/professional codes and regulations.

Ensure all labels on the boiler are legible. All connections and safety devices, both mechanical and electrical, must be kept clean, with ease of access for inspection, use and maintenance.

Do not store or use gasoline or other flammable vapors and liquids or corrosive materials in the vicinity of this or any other appliances.

⚠ CAUTION

The hydronic system should never be flushed while the boiler is attached to the system since the debris could accumulate in the boiler and block water from passing through the heat exchanger.

The upper water connection is the boiler supply (outlet). The lower water connection is the boiler return (inlet).

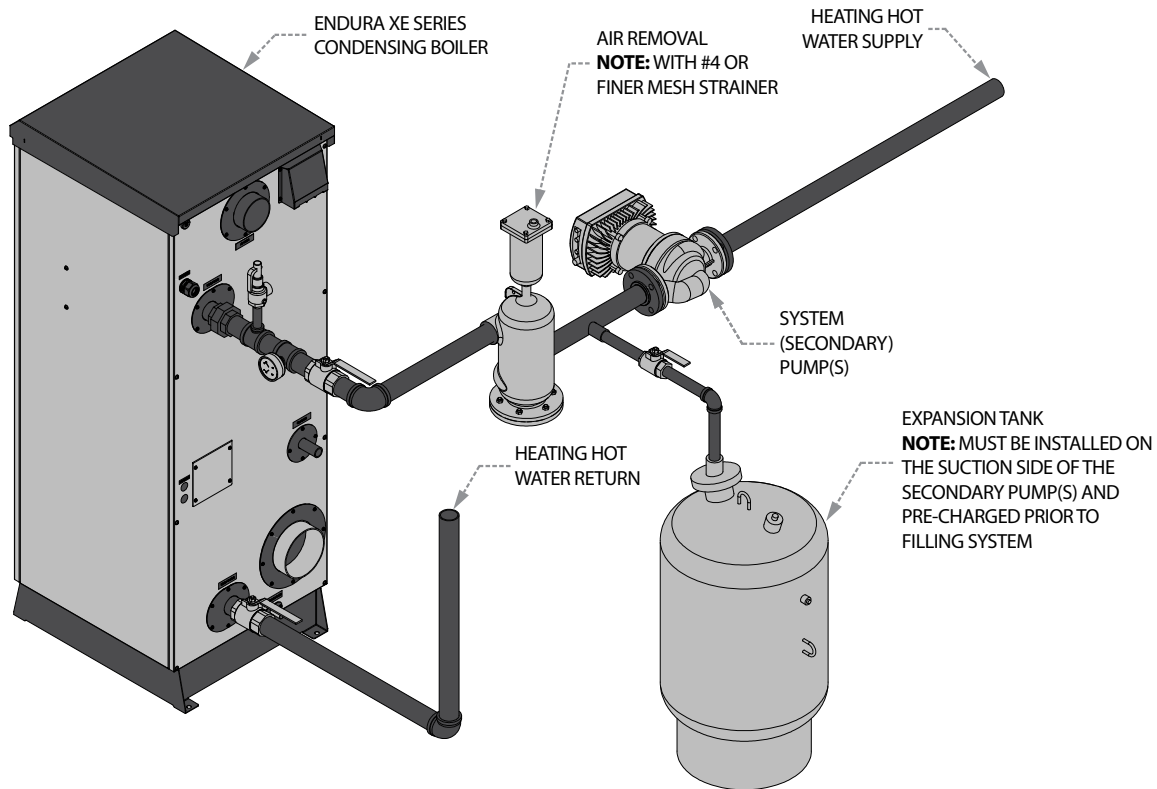

FIGURE 4 - SAMPLE PIPING LAYOUT, PRIMARY ONLY VARIABLE FLOW PIPING; SINGLE BOILER

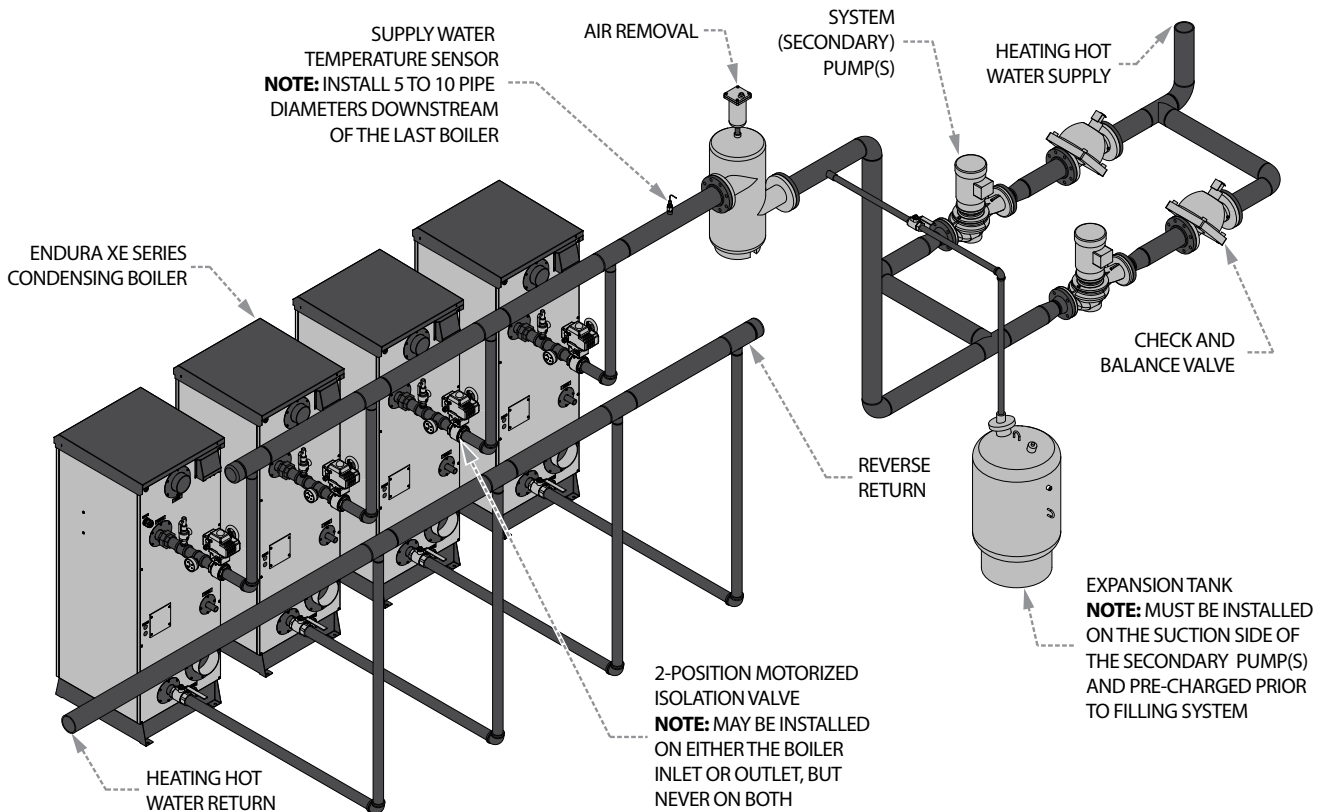

FIGURE 5 - SAMPLE PIPING LAYOUT, PRIMARY ONLY VARIABLE FLOW PIPING; MULTIPLE BOILERS

Note: Sample piping layout (P&ID) is a general representation of system installation. Good practice should be used in system design, including but not limited to adequate pipe/valve sizing and natural flow path for system water.

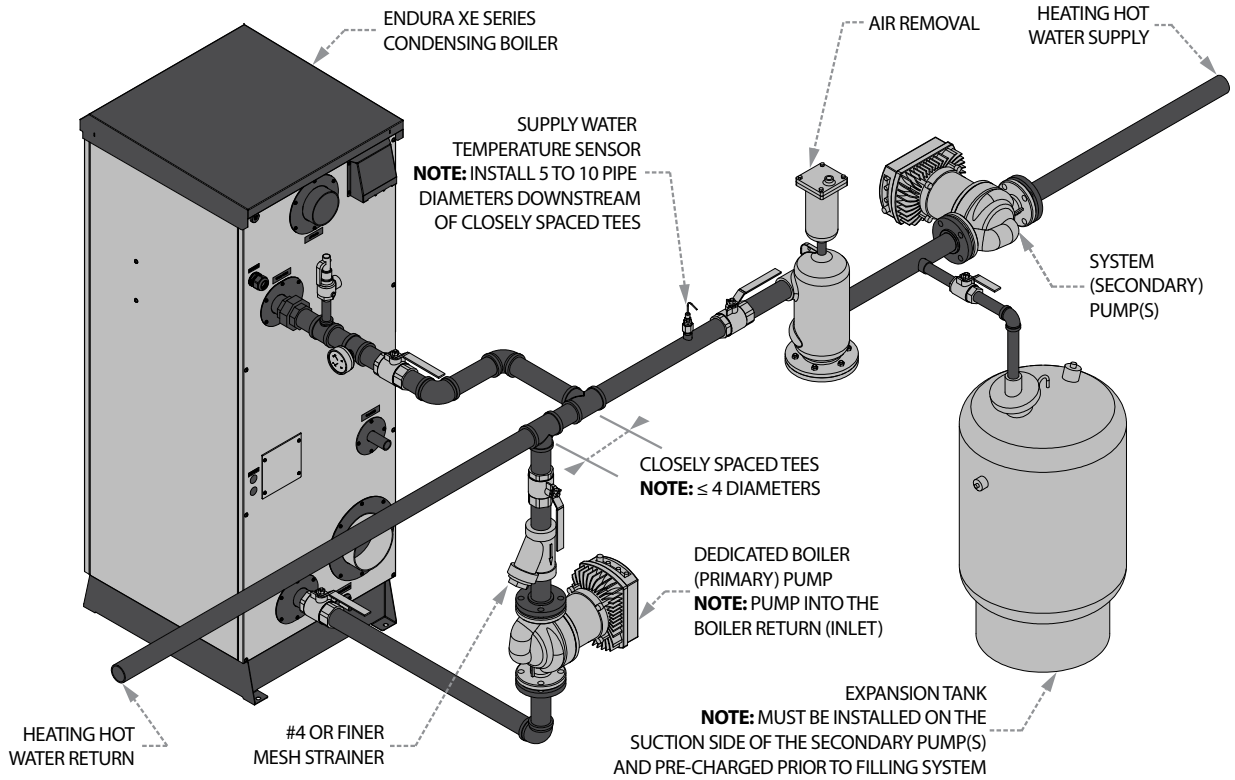

FIGURE 6 - SAMPLE PIPING LAYOUT, PRIMARY - SECONDARY PIPING; SINGLE BOILER

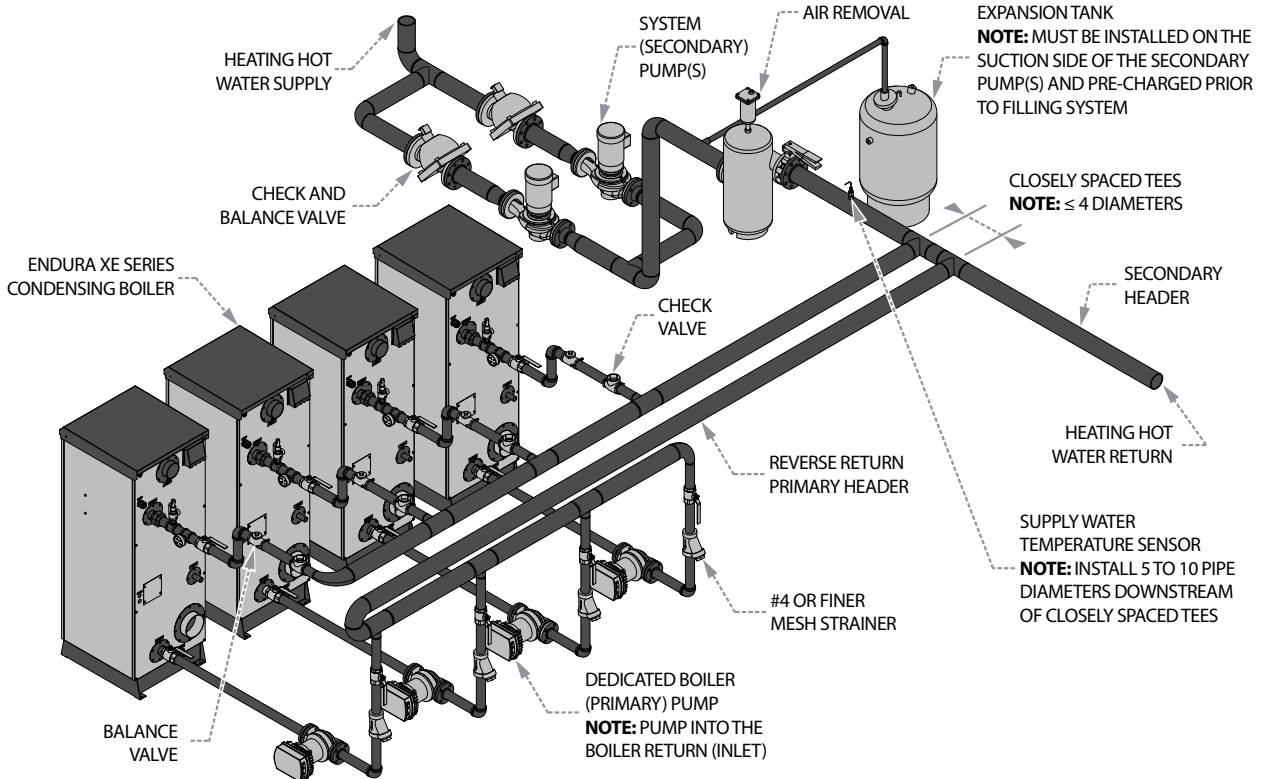

FIGURE 7 - SAMPLE PIPING LAYOUT, PRIMARY - SECONDARY PIPING; MULTIPLE BOILERS

Note: Sample piping layout (P&ID) is a general representation of system installation. Good practice should be used in system design, including but not limited to adequate pipe/valve sizing and natural flow path for system water.

WARNING

All information in this manual is for reference and guidance purposes, and does not substitute for required professional training, conduct, and strict adherence to applicable jurisdictional/professional codes and regulations.

Do not use matches, candles, flame or other sources of ignition to check for gas leaks.

CAUTION

Ensure process fluid (water) side of the boiler remains above 32°F (0°C) while in storage or operation.

- Only use one isolation valve per boiler; two-position type actuator, open or closed. It is acceptable to install the valve on either the inlet or the outlet piping of each boiler, but never both. Select a valve actuator with a cycle time of 45 seconds or less. Do not install modulating isolation valves on boiler piping.
- Ensure flow paths in the hydronic loop and residual heat in the pressure vessel is adequately dispersed for sufficient time after the burner is disabled. The valve control system must be capable of leaving the lead boiler valve open at all times.
- Use a reverse return header to balance flow across the boilers. Where reverse return cannot be used, it is recommended to install a balancing valve per boiler.
- Do not install three-way mixing valves or minimum temperature protection. This boiler does not have a minimum return water temperature requirement.
- Install system bypass valve(s) at or after the last coil(s), do not install bypass valves directly after the secondary (system) pump(s).

■ Primary-Secondary Piping Arrangement

It is acceptable to install this boiler in a primary-secondary arrangement, although this arrangement is not required. See **Figures 6** and **7**. Primary-secondary arrangements are used to decouple the water flow of the primary (boiler) loop from the secondary (system) loop. Blending occurs in the shared piping region.

Adhere to the following for primary-secondary piping arrangements:

- Typical decoupling methods include closely spaced tees, a buffer tank, or a hydraulic separator. Where using closely spaced tees, separate by four pipe diameters or less.
- Install the dedicated boiler circulator on the inlet side of the boiler, pumping into the return connection. Select pump(s) with sufficient total dynamic head for the pressure drop of the loop at design flow. See **Figure 3** for the boiler water pressure drop.
- For multiple boiler systems:
 - » A check valve is required per boiler. Motorized isolation valves are not an acceptable substitute for check valves. Use a single common supply and a single common return connection into the secondary (system) piping. Do not use separate connections for each boiler into the secondary piping.
 - » Use a reverse return primary header to balance flow across the boilers. Where reverse return cannot be used, it is recommended to install a balancing valve per boiler.

Meet Water Chemistry Requirements

System water chemistry requirements are as follows:

- pH: Range of 8.5 - 10.5
- Oxygen: Less than 250 ppb (operating condition)
- Total Iron/Copper: Less than 5 ppm
- Corrosion Inhibitor: Capable of maintaining iron corrosion rates <2 mpy. Due to changing environmental restrictions a non-heavy metal ALL ORGANIC inhibitor is recommended which is designed for multi metal systems including ferrous metals and yellow metals such as copper and brass.
- Chloride: Less than 200 ppm
- Hardness: Less than 3.5 grains per gallon (60 ppm) in make-up/fill water. Calcium buildup on heating surfaces is not covered under warranty.

Adhere to the following:

1. Refer to your water conditioning or chemical treatment supplier for analysis and recommendations for proper system conditions.
 2. Follow a program with appropriate monitoring and maintenance of system water conditions as provided by your water conditioning or chemical treatment supplier.
 3. If RO/DI water is used as a source for hydronic loop water or makeup water, it must be neutralized to a pH of 8.5 - 10.5 prior to entering the boiler. Failure to neutralize the RO/DI water will void the pressure vessel warranty and may cause high general corrosion rates.
 - The system must have an automatic pH controller to monitor and log the levels. This must be independent of other chemical feed systems.
 - Makeup water pH range must be 7.5 - 8.8; the boiler water must be maintained within pH range of 8.5 - 10.5.
 4. Operate the boiler in a closed-loop system using water or water/glycol (not requiring a make-up water supply). A large amount of improperly treated make-up water can cause premature failure of the heat exchanger resulting from scale build up. Scale build up will reduce the efficiency and useful life of the boiler and is not covered under warranty.
 5. For freeze protection, an inhibited propylene glycol is recommended. The maximum concentration is 50% glycol by volume. Only use mixtures formulated for hydronic systems. DOWFROST™ HD is recommended. Do not use automotive glycol.
- **NOTE:** For systems using up to 50% glycol, a minimum 30 psi fill pressure is required at the boiler outlet.
6. At a minimum, the hydronic fluid should be checked for glycol concentration and pH once a year, or per glycol manufacturer schedule. A refractometer is recommended.

WARNING

All information in this manual is for reference and guidance purposes, and does not substitute for required professional training, conduct, and strict adherence to applicable jurisdictional/professional codes and regulations.

CAUTION

This hydronic heating boiler is not suitable for use as a domestic water heater. Do not heat potable water, such as used for showers, sinks, dishwashers, or washdown process directly through the boiler.

Care needs to be taken to eliminate oxygen from the water system, as excess oxygen in the system will reduce the life of any boiler. The boiler warranty does not cover heat exchanger replacement due to oxygen contamination of boiler water.

Proper water filtration and treatment are essential to ensure the longevity and efficiency of the boiler. Failure to adhere to water quality requirements will reduce the useful life of any boiler. Water side damage or failure of the heat exchanger is not covered under warranty. This includes but is not limited to damage from particulates, foreign matter, debris, excess oxygen, glycol degradation, fouling, scale buildup, and corrosion.

For systems using up to 50% glycol, a minimum 30 psi fill pressure is required at the boiler outlet.

■ Prevent Oxygen Contamination

There are several ways to prevent boiler water oxygen contamination:

- Minimize system leaks to minimize make up water requirement.
- Do not use open tanks or fittings.
- Do not use oxygen permeable materials anywhere in the water system.
- Repair leaks in the system quickly.
- Eliminate fittings wherever possible.
- Use air elimination devices in system piping.

■ Eliminate System Air

► *NOTE: There are no built-in boiler air eliminating features.*

Adhere to the following for air elimination:

1. The installation of an air separator and air eliminator (air vent) is required.
2. To prevent scale corrosion in boiler and associated piping, make up water must be kept to a minimum. This is best achieved by ensuring immediate repair of all leaks and that system pressure is maintained.
3. If a sealed diaphragm-type expansion tank is used, install an air eliminator in the hot water piping at the air separator on the suction side of the system circulator(s).
4. If an air cushion type expansion tank is used, pipe tank directly into boiler supply on the suction side of the system circulator(s).
5. On multi-zoned systems (or a system with both space and domestic water heating), air elimination must be provided either in the common piping or on every loop.
6. When the boiler is installed at a higher level than baseboard radiation (if used), air elimination must be provided directly above the unit.

Fill the Boiler With Water

To be sure that the boiler is not air-bound, open the pressure-relief valve located at the rear of the boiler. Leave the relief valve open until a steady flow of water is observed. Close the valve and finish filling the system.

Gas Supply Piping

The boiler features a gas fired fully modulating burner requiring gas delivery at a relatively constant pressure and calorific content. This ensures efficient and reliable combustion.

The gas train (See **Figure 8**) pressure requirements are detailed in **Table 1** and on the boiler data plate located at the rear of the boiler. Do not modify the factory gas train.

This boiler is factory test fired and combustion is adjusted per the Factory Test Fire Report.

■ Inlet Gas Pressure

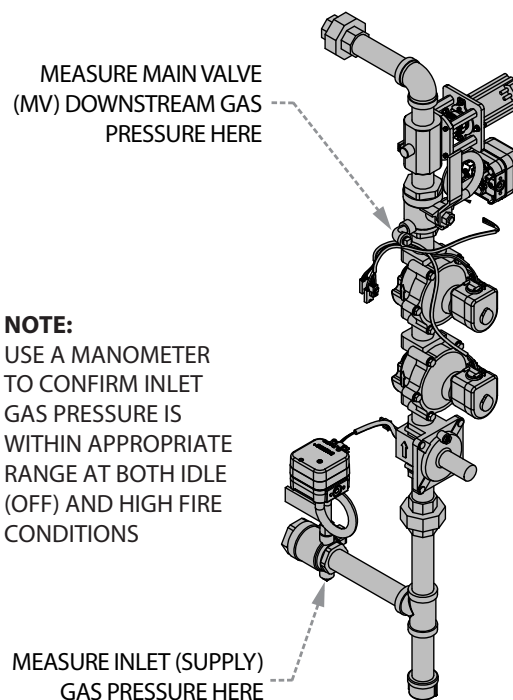

FIGURE 8 - MEASURING INLET GAS PRESSURE

Measure at the location shown in **Figure 8** and adhere to the following:

1. Static inlet gas pressure: Measure while boiler is idle. Verify pressure is within allowable range.
2. Dynamic inlet gas pressure: Measure while boiler is in operation at maximum firing rate. Verify pressure is within allowable range.
3. The gas delivery system must provide a stable and consistent pressure across the entire turndown range, including light off and idle conditions.
4. Insufficient gas pressure may impact operation or result in boiler derate. It is recommended to size the field gas piping to ensure inlet gas pressure drop between low fire and high fire does not exceed the following or the maximum allowable by local code (CSA B149 clause 6.3.2, 6.3.3 for Canada):
 - For inlet gas pressure less than 7"W.C. 0.5"W.C.
 - For inlet gas pressure 7 to 14"W.C. 1"W.C.

▪ Line Gas Pressure Regulation

When inlet gas pressure exceeds 14"W.C. a line gas regulator (not provided) listed and labeled to ANSI Z21.80/CSA 6.22 will be used to step the gas pressure down below the boiler's maximum gas pressure.

Proper selection and installation of a gas pressure regulator is essential in providing conditions for efficient and reliable combustion. Adhere to the following guidelines when selecting and installing a gas pressure regulator:

- A line pressure regulator listed and labeled to ANSI Z21.80/CSA 6.22 is recommended. Lock-up is defined as an outlet pressure not more than 150% or 5"W.C., whichever is greater, above the setpoint after a downstream safety shutoff valve closes within 2 seconds. Appliance regulators are not a substitution for line gas pressure regulators and must not be used.
- A gas pressure relief valve may be required for overpressure protection, refer to the local code(s) adopted by the AHJ.
- A sediment trap is recommended prior to the inlet of the regulator.
- If the level of pipe system cleanliness is unacceptable or unknown, it is recommended that a gas filter be installed prior to the regulator.
- On the outlet of the regulator: Install a straight and uninterrupted section of pipe matching regulator connection size with a minimum length of 10 pipe diameters prior to any valves or fittings.
- When installed in close proximity to an appliance, some regulators may experience oscillation (hunting) or an outlet pressure spike when demand ends. Provide adequate volume by locating the regulator a recommended minimum of 10 total linear feet of pipe from boiler fuel train inlet. Consult the regulator manufacturer for installation requirements.
- The body size should never be larger than the pipe size. However, a properly sized regulator may be smaller than the pipe size.



WARNING

All information in this manual is for reference and guidance purposes, and does not substitute for required professional training, conduct, and strict adherence to applicable jurisdictional/professional codes and regulations.

This hydronic heating boiler is not suitable for use as a domestic water heater. Do not heat potable water, such as used for showers, sinks, dishwashers, or washdown process directly through the boiler.



CAUTION

Some soap used for leak testing is corrosive to certain types of metals. Clean all piping thoroughly after.

The gas burner is designed for operation on standard Natural Gas with up to 20% Hydrogen content or consumer-grade HD5 Propane only. Do not operate the boiler on Biogas, Digester Gas, Methane, Waste Gas, Landfill Gas, Synthetic Natural Gas or any other reclaimed or manufactured byproduct gases. Use of unapproved fuels may result in improper combustion, corrosion or damage to the burner, heat exchanger or other components. Such damage is not covered under warranty.

- The inlet pressure used for sizing should be measured directly at the regulator inlet. Measurements taken at any other point may be subject to losses associated with upstream piping.
- Consult the regulator manufacturer for orifice selection.
- If two or more springs are available for a particular outlet pressure in the desired range use the spring with the lower range for better accuracy.
- For multiple boiler installations it is recommended that an individual line gas pressure regulator be used to step-down the gas pressure at each boiler. Where a single regulator is used for multiple boilers the regulator must be appropriate for the entire gas delivery turndown range. This includes all boilers on at full fire to one boiler on at low fire.

■ Gas Piping Installation

Field gas piping must be installed in accordance with NFPA 54 National Fuel Gas Code, ANSI Z223.1, and any other local codes which may apply. Adhere to the following for gas piping installation:

1. See **Table 3** for required natural gas pipe size, based on overall length of pipe from the meter plus equivalent length of all fittings. Approximate sizing may be based on 1,020 BTU for 1 cubic foot of natural gas. See **Figure 9** for the typical field piping arrangement.
2. Piping must be of the proper size to ensure adequate gas supply. It is typical for gas delivery piping to be up-sized one or several diameters larger than boiler gas inlet size.
3. The pipe and the fittings used must be new and free of dirt or other deposits.
4. When making gas-piping joints, use a sealing compound resistant to the fuel gas serving the boiler.
5. Install a manual gas shutoff valve and union (not supplied) prior to the boiler.
6. Piping must be installed such that no piping stresses are transmitted to the boiler. The boiler cannot be used as a pipe anchor.
7. All gas piping connections must be checked for leaks before being placed into service. Test with compressed air or inert gas if possible.
8. The boiler gas train must be disconnected at the boiler manual shutoff valve from the gas supply piping system during any pressure testing of the system at pressures in excess of 0.5 psig (14 inch W.C.).
9. After completing pressure testing and obtaining any necessary approvals from the AHJ, introduce gas service and purge gas piping in accordance with local codes. Do not purge their contents into a confined space or where fuel gas can accumulate.
10. The boiler gas train has been factory leak tested, however, fittings may loosen during shipping or installation. After gas piping is completed and before wiring installation is started, all piping connections (factory and field) must be carefully checked for gas leaks. Use a soap and water solution or combustible gas detector. A GAS-Mate® 0119 or equivalent is recommended.

■ Components Requiring Ventilation to the Outdoors

An authority having jurisdiction (AHJ) may not permit the use of a vent limiter on some or all components. If venting is required, use the following general guidelines:

- Drill an appropriately sized penetration for each vent line through the topmost panel on the rear of the boiler cabinet. Do not install any vent lines through removable panels. Properly seal around the pipe with silicone to maintain a sealed cabinet and ensure combustion air will not bypass the filter.
- Each component must have a separate vent line to the outdoors. Vent lines must not be manifolded or combined with any other vent or exhaust systems.
- Start with the vent connection size and as soon as it is practical, increase the pipe size one diameter. For every ten feet of vent, increase the pipe size one diameter. Never reduce the vent size.
- Protect the vent termination from debris, dust and insects. Install the vent termination above the snow line and point down to prevent ingress of water. The termination must be a minimum of 3 ft (0.9 m) from a source of ignition.

TABLE 3 - SCH 40 PIPE NATURAL GAS CAPACITY

Nominal Pipe Size	ID	Equivalent Pipe Length		Max Capacity in ft ³ of natural gas per hour. 14"wc pressure. Pressure drop of 0.5"wc. Equivalent length of pipe (feet)						
		90 Elb Feet (meter)	Tee Feet (meter)	20	40	60	80	100	150	200
1-1/4 (31.75)	1.380 (35.05)	3.45 (1.05)	6.9 (2.10)	950	-----	-----	-----	-----	-----	-----
1-1/2 (38.1)	1.610 (40.89)	4.02 (1.22)	8.04 (2.45)	1460	990	810	-----	-----	-----	-----
2 (50.8)	2.067 (52.50)	5.17 (1.57)	10.3 (3.13)	2750	1900	1520	1300	1150	950	800
2-1/2 (63.5)	2.469 (62.71)	6.16 (1.87)	12.3 (3.74)	4350	3000	2400	2050	1850	1500	1280
3 (76.2)	3.068 (77.92)	7.67 (2.33)	15.3 (4.66)	7700	5300	4300	3700	3250	2650	2280
4 (101.6)	4.026 (102.26)	10.10 (3.07)	20.2 (6.15)	15800	10900	8800	7500	6700	5500	4600
6 (152.4)	6.07 (154.17)	10.10 (3.07)	23.60 (7.19)	-----	-----	-----	-----	20200	16503	12766
8 (203.2)	7.98 (202.69)	13.30 (4.05)	29.10 (8.86)	-----	-----	-----	-----	41200	33660	29128

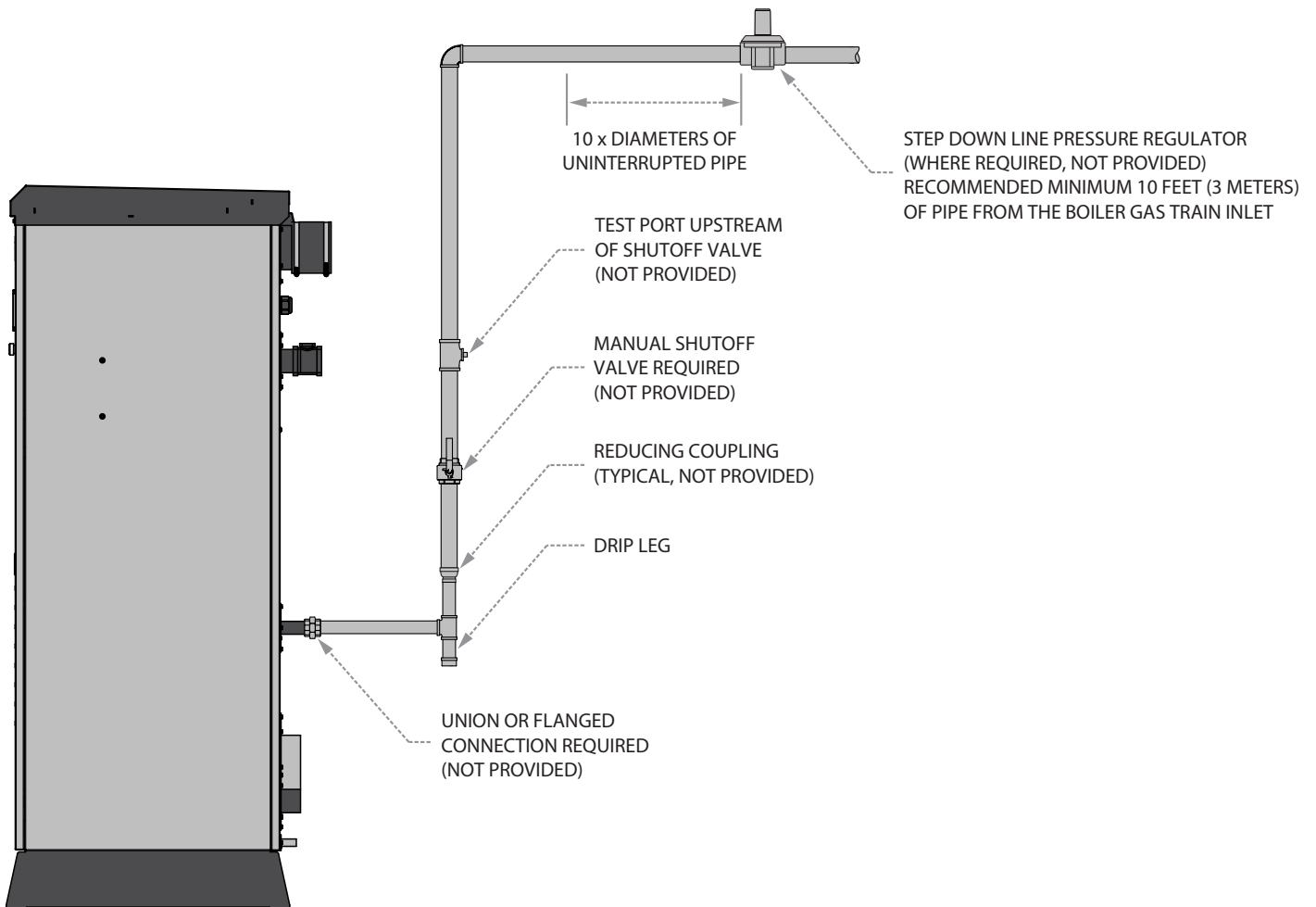

FIGURE 9 - FIELD GAS SUPPLY PIPING

Install Condensate Drain Trap

A condensate drain trap is used to allow flue gas condensate to freely drain while preventing the escape of combustion exhaust gases into the mechanical space.

The drain trap must be configured one per boiler. Do not manifold drain lines.

Refer to **Figure 10** and adhere to the following for installation:

1. The 3/4 inch (19 mm) condensate drain connection on the boiler will be connected to the 3/4 inch (19 mm) inlet on the condensate drain trap.
2. A condensate collecting tank and condensate pump will be required if a floor drain is not available (not provided) at a suitable location.

3. Flue gas condensate drain lines must be silicone tube, PVC, CPVC, or stainless steel. A barbed to NPT fitting (not provided) can be used to connect silicone tube to rigid pipe. Do not use copper or steel/iron pipe, these materials are not suitable.
4. The drain trap must be installed below the boiler condensate drain outlet.
5. Connect the condensate trap outlet to an appropriate waste line following applicable codes. The outlet connection on the trap must be the highest point prior to going to the drain. Failure to keep drain piping lower than this point will result in overflow of the trap. Slope the drain pipe away at a minimum pitch of 1 inch (25.4 mm) for every 12 feet (3.65 m).

► **NOTE:** Ensure piping will not be exposed to freezing temperatures.

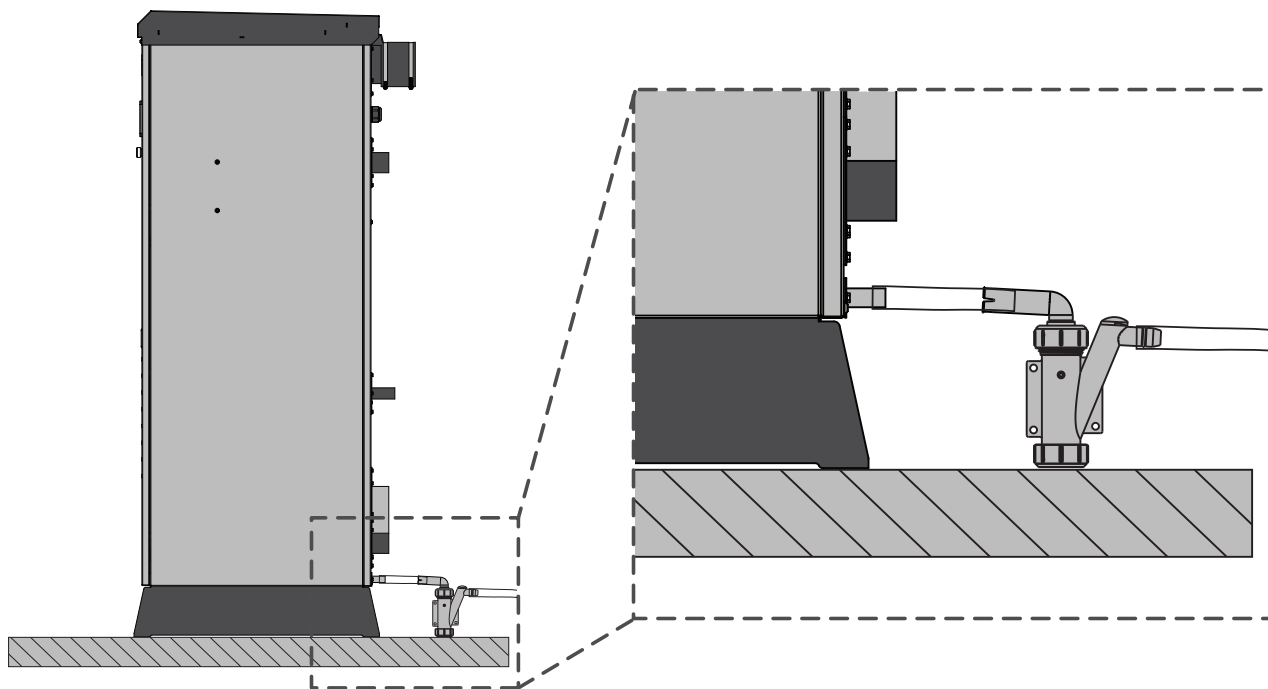

NOTES:

1. A FLUE GAS CONDENSATE TRAP IS USED TO PREVENT THE ESCAPE OF COMBUSTION GASES INTO THE MECHANICAL SPACE AND MUST BE INSTALLED AND FUNCTIONAL WHILE THE BOILER IS IN OPERATION.
2. FLUE GAS CONDENSATE DRAIN LINES MUST BE PITCHED DOWN MINIMUM 1-INCH (25 MM) PER 12-FEET (3.7 M) TOWARDS THE DRAIN.
3. FLUE GAS CONDENSATE DRAIN LINES MUST BE PVC, CPVC, STAINLESS STEEL, OR SILICONE TUBE. DO NOT USE COPPER OR MILD STEELS, THESE MATERIALS ARE NOT SUITABLE.
4. THE FLUE GAS CONDENSATE TRAP MUST BE LOWER THAN THE CONDENSATE DRAIN OUTLET OF THE BOILER.
5. ONE (1) FLUE GAS CONDENSATE TRAP MUST BE INSTALLED PER EACH BOILER, DO NOT MANIFOLD DRAIN LINES.

FIGURE 10 - CONDENSATE DRAIN PIPING

Install pH Neutralizer

The pH Neutralizer is used to bring the pH level of the boiler's condensate to a more neutral level. It is not a replacement or alternative for the Condensate Drain Trap. See **Figure 11**.

Adhere to the following for pH Kit installation:

1. Use PVC, CPVC, stainless steel, or silicone tube and fittings to connect condensate trap to the neutralizer.
 2. Connect neutralizer downstream of Condensate Drain Trap.
 3. Pipe outlet to appropriate drain.
 4. Check condensate pH periodically.
- *NOTE: Replacement medium is available from your Fulton local representative.*

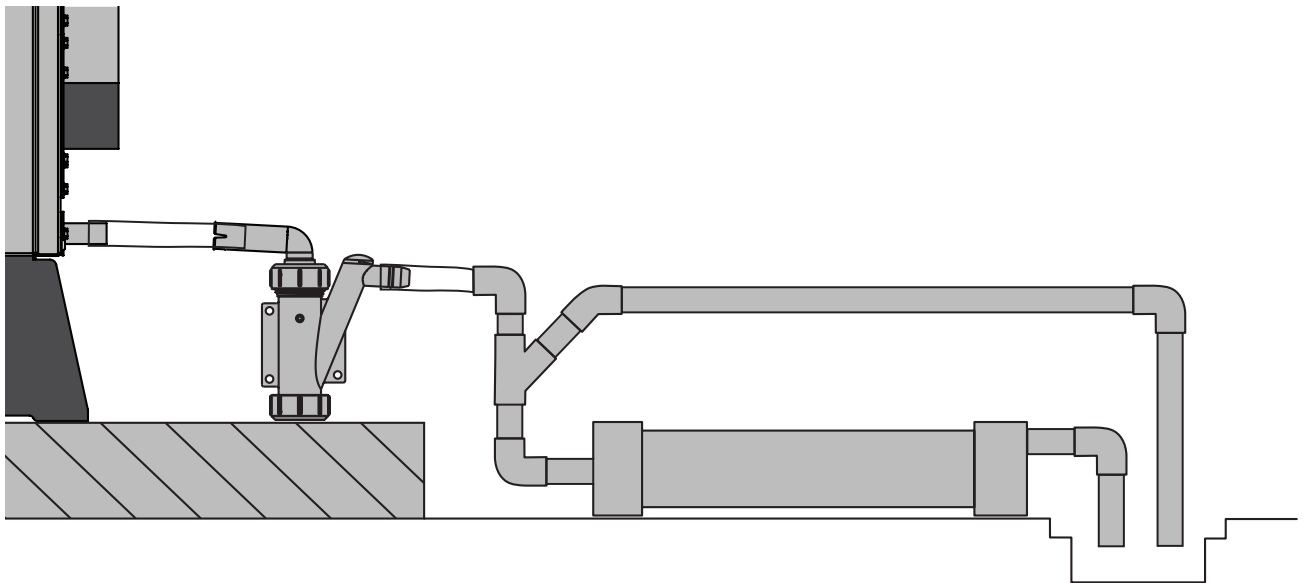

NOTES:

1. A PH NEUTRALIZER IS USED TO RAISE THE PH OF THE ACIDIC FLUE GAS CONDENSATE PRIOR TO DISPOSAL INTO THE FLOOR DRAIN.
2. A PH NEUTRALIZER IS NOT REQUIRED FOR BOILER OPERATION, BUT MAY BE REQUIRED BY THE LOCAL AUTHORITY HAVING JURIDCTION (AHJ). CONSULT YOUR LOCAL AHJ FOR REQUIREMENTS.
2. FLUE GAS CONDENSATE DRAIN LINES MUST BE PITCHED DOWN MINIMUM 1-INCH (25 MM) PER 12-FEET (3.7 M) TOWARDS THE DRAIN.
3. FLUE GAS CONDENSATE DRAIN LINES MUST BE PVC, CPVC, STAINLESS STEEL, OR SILICONE TUBE. DO NOT USE COPPER OR MILD STEELS, THESE MATERIALS ARE NOT SUITABLE.
4. THE PH NEUTRALIZER MUST BE LOWER THAN THE OUTLET OF THE CONDENSATE DRAIN TRAP.
5. AN OPTIONAL OVERFLOW BYPASS LINE MAY BE INSTALLED IN THE EVENT THE PH NEUTRALIZER BECOMES BLOCKED OR RESTRICTED. ENSURE OVERFLOW BYPASS LINE IS ABOVE THE PH NEUTRALIZER AND BELOW THE OUTLET OF THE CONDENSATE DRAIN TRAP.
6. PROVIDE ACCESS TO THE PH NEUTRALIZER FOR ROUTINE TESTING AND MAINTENANCE OF THE NEUTRALIZING MEDIA.

FIGURE 11 - FIELD CONNECTIONS FOR CONDENSATE DRAIN TO PH NEUTRALIZATION TANK

WARNING

All information in this manual is for reference and guidance purposes, and does not substitute for required professional training, conduct, and strict adherence to applicable jurisdictional/professional codes and regulations.

The installer must verify that at least one carbon monoxide alarm has been installed within a residential living space or home following the alarm manufacturer's instructions and applicable local codes before putting the appliance into operation.

This product burns fuel gas to produce heat. The appliance must be properly installed, operated, and maintained to avoid exposure to appreciable levels of carbon monoxide and the installer is required to confirm that at least one carbon monoxide alarm is installed in the living space before the appliance is put into operation. It is important for the carbon monoxide alarms to be installed, maintained, and replaced following the alarm manufacturer's instructions and applicable local codes.

CAUTION

The boiler must not be installed in the same room as refrigeration containing equipment such as a chiller or heat pump unless a refrigerant detector is installed and interlocked with the boiler to shut down the burner in the event of refrigerant leakage. This requirement must be met for all installations including where combustion air is ducted from the outdoors.

Particulate matter or chemicals (example: chlorine, sulfur, fluorocarbon refrigerants, fluorine, perchlorethylene, halogenated compounds) in the combustion air supply to the boiler will cause damage or failure to the burner and heat exchanger. Damage due to air contamination is not covered under warranty.

Venting Requirements

TABLE 4 - VENTING GENERAL REQUIREMENTS

<p>Maximum Combined Pressure Loss: Net total absolute values of friction losses ("delta-p") of both the combustion air intake duct (if used) and flue gas exhaust vent systems must not exceed this value.</p>	1.25 "W.C.
<p>Maximum Negative Draft: The stack effect (draft, negative vent pressure) as measured at the boiler flue gas outlet relative to the room pressure must not exceed this value.</p>	- 0.10 "W.C.
<p>Typical Maximum Equivalent Length (CAI): Approximate maximum equivalent length of the combustion air intake (CAI) system. Equivalent lengths can vary by manufacturer, material, installation methods and site conditions. Consult your vent supplier for more details.</p>	100 feet
<p>Typical Maximum Equivalent Length (Flue Gas Vent): Approximate total maximum equivalent length of the flue gas vent system. Equivalent lengths can vary by manufacturer, material, installation methods and site conditions. Consult your vent supplier for more details.</p>	100 feet
<p>Mechanical Room Pressure: Ensure there is not a negative pressure in the boiler room. For safe and reliable operation, the mechanical space ventilation system must maintain a neutral pressure relative to the outdoors.</p>	0.0 "W.C.

► NOTE: Equivalent length is not the same as total linear length. Consult your venting supplier for the equivalent length values of fittings.

Adhere to the following venting requirements:

1. This boiler can operate to the combined intake and flue exhaust pressure drops without altering standard capacities: See **Table 4**.
2. The combined venting system draft pressure readings at the boiler exhaust connection and air intake connection cannot exceed the maximum value stated in **Table 4**; and must remain relatively stable throughout all operating conditions, including the ignition sequence.

► NOTE: Venting pressure is the combined result of frictional pressure drop and natural draft (stack effect) in the combustion air intake piping (if used) and flue gas exhaust vent system.

3. Drastic draft changes during operation may result in the generation of excessive carbon monoxide or soot, which may affect operational reliability and condition of burner, ignition assembly, or other combustion system components leading to increased wear and maintenance.
4. The equivalent length method is not a replacement for good engineering practices for determining acceptability of a vent system due to varying burner modulation rates, ambient air temperatures, and flue gas temperatures, among other factors. Combustion air intake piping (if used) must be accounted for in an analysis of the venting system.

5. If the maximum positive pressure loss is exceeded, the boiler may have to be de-rated or require the installation of draft accessories such as an engineered exhaust assist fan to prevent operational issues from occurring. If the maximum negative pressure is exceeded due to excessive natural draft (stack effect), the exhaust system may require the use of draft accessories such as a fixed-position balancing baffle or modulating overdraft damper. Draft accessories must be appropriate for Category II/IV installations and are not included with the boiler. Consult your venting supplier for recommendations.
6. Adhere to local and jurisdictional codes and regulations, which may differ from recommendations and diagrams contained in this manual.
7. Site specific conditions not addressed in this manual may require additional precautions or design considerations. Consult your local Fulton Representative and venting supplier for recommendations.

► **NOTE:** Consult your venting pipe supplier for assistance with sizing of vent materials and other potentially required accessories.

8. The layout of the piping used for air intake and exhaust must be done in a way that facilitates smooth travel and natural flow.
9. A pressure drop calculation is an acceptable method for evaluating theoretical draft, but is not enough information to fully validate combustion air intake and flue gas exhaust vent systems. The designer and installer must use good practice and remain cognizant of important factors that cannot be captured by a pressure drop calculation such as local code requirements, accessibility for inspection and maintenance, aesthetic concerns, flue gas recirculation, stagnant vapor plumes, prevailing wind direction, nearby mechanical equipment and other design considerations as detailed in this manual. Some recommendations:
 - Avoid sharp turns, boot tees, bullhead tees, back-to-back 90 degree elbows, and short radius elbows.
 - Avoid extensive direction changes (flue gases being required to turn around).
 - Never direct flue stacks in a downward direction.

Combustion Air Intake

Adhere to the following for installation:

1. It is the responsibility of the designer and installer of the venting system to guarantee the prevention of flue gas recirculation. This includes particular care to prevent flue gases being drawn into a boiler's combustion air supply, or flue gases moving backward through an idle boiler.
2. Under no circumstances should the boiler room be under a negative pressure. The boiler room must be maintained at a neutral pressure relative to the outdoors. Avoid the use of room exhaust fans and ensure other equipment such as compressors, clothes dryers, air handling units and water heaters will not create a negative pressure space. A negative boiler room can create down draft in the stack, affect gas regulation, or restrict the burner's air supply, resulting in poor combustion or life safety hazard.



WARNING

All information in this manual is for reference and guidance purposes, and does not substitute for required professional training, conduct, and strict adherence to applicable jurisdictional/professional codes and regulations.



CAUTION

The boiler must not be installed in the same room as refrigeration containing equipment such as a chiller or heat pump unless a refrigerant detector is installed and interlocked with the boiler to shut down the burner in the event of refrigerant leakage. This requirement must be met for all installations including where combustion air is ducted from the outdoors.

Ensure there is not a negative pressure in the boiler room. The boiler room pressure must be neutral relative to the outdoors.

Particulate matter or chemicals (example: chlorine, sulfur, fluorocarbon refrigerants, fluorine, perchlorethylene, halogenated compounds) in the combustion air supply to the boiler will cause damage or failure to the burner and heat exchanger. Damage due to air contamination is not covered under warranty.

WARNING

Do not terminate venting into an enclosed area.

Never use open flame or smoke from a cigarette, cigar, or pipe as a testing method during boiler installation, operation, or maintenance.

Foreign substances, such as combustible volatiles in the combustion system can create hazardous conditions.

CAUTION

The boiler must not be installed in the same room as refrigeration containing equipment such as a chiller or heat pump unless a refrigerant detector is installed and interlocked with the boiler to shut down the burner in the event of refrigerant leakage. This requirement must be met for all installations including where combustion air is ducted from the outdoors.

Ensure there is not a negative pressure in the boiler room. The boiler room pressure must be neutral relative to the outdoors.

Particulate matter or chemicals (example: chlorine, sulfur, fluorocarbon refrigerants, fluorine, perchlorethylene, halogenated compounds) in the combustion air supply to the boiler will cause damage or failure to the burner and heat exchanger. Damage due to air contamination is not covered under warranty.

3. It is essential that only fresh air is allowed to enter the combustion air system. Foreign substances, such as combustible volatiles in the combustion system can create hazardous conditions.
4. Particulate matter (example: sheetrock, fiberglass, cement, plaster board, dirt, dust, lint) or chemicals (example: chlorine, sulfur, freon, fluorine, perchlorethylene, halogenated compounds) in the combustion air supply to the boiler will cause damage or failure to the heat exchanger and/or burner, and is not covered under warranty. High-risk situations for particulate matter to be in the air include construction and maintenance activities. See **Table 5**.

► *NOTE: Pool and laundry room air may be contaminated with chlorine or fluorine compounds. If allowed to enter the combustion air supply, these contaminants will significantly increase the acidity of flue gas condensate, potentially damaging heat transfer surfaces. Damage to the heat exchanger due to poor combustion air quality is not covered under warranty.*

TABLE 5 - PRODUCTS/CONTAMINANTS TO AVOID

Products to avoid	Products containing chloro/flouorocarbons; chlorine-based products; calcium chloride products, sodium chloride products, paint and varnish removers, hydrochloric acid, muriatic acid, cements, glues, antistatic fabric softeners, Freon, drywall particles, dirt, fiberglass
Areas with the potential to have contaminants	Dry cleaning/laundry areas; swimming pools; repair shops; processing plants; manufacturing plants; active construction sites; chemical storage; food processing plants; farms, cooling towers, chillers

■ Combustion Air Supply From the Boiler Room

Refer to **Figure 16** and adhere to the following for installation:

1. A room air kit is required.
2. Adequate combustion air and ventilation must be supplied to the boiler room in accordance with local codes and NFPA54/ANSI Z233.1, Section 9.3, Air for Combustion and Ventilation or CSA-B149.1 for Canada. The minimum net free area requirements in **Table 6** may not supersede local and jurisdictional codes and regulations where there codes and regulations require an opening of greater net free area. The boiler room must meet the NFPA criteria for a non-confined space.
3. Verify combustion air is taken from the outdoors and not from the inhabited or occupied spaces within the building. Ensure space and nearby products are evaluated for the potential of combustion air contaminants. See **Table 5**.
4. For installations providing two permanent openings directly communicating with the outdoors, the minimum net free area of each opening is 1 in² per 4,000 BTU/hr of the total input capacity of the combined burners located in the boiler room. Ensure a high opening commences within 12 inches of the ceiling, and a low opening commences within 12 inches of the floor. See **Table 6**.

- For installations providing a single permanent opening directly communicating with the outdoors, the minimum net free area of the opening is 1 in² per 3,000 BTU/hr of the total input capacity of the combined burners located in the boiler room. See **Table 6**.
- For multiple boiler installations, multiply the number of boilers by required net free area per boiler.

TABLE 6 - MAKE-UP AIR VENTILATION OPENINGS

Boiler Input Capacity (MBTU/HR)	Two Openings Min. Net Free Area Each (SQFT)		Single Opening Only Min. Net Free Area (SQFT)
	Low	High	
399	0.7	0.7	0.9
500	0.9	0.9	1.2
600	1.1	1.1	1.5
750	1.3	1.3	1.7

- The net free area required for the boiler(s) is in addition to the combustion or ventilation air supply requirements of other equipment sharing the same space such as water heaters, generators, air compressors, or other boilers. The boiler room must have an opening or openings not less than the total net free area required for all types of equipment.
- Consider the blocking effects of louvers, grills, and screens on the net free area of each opening. Ensure ventilation openings are unobstructed.
- Where mechanical combustion air supply systems are used, such as a combustion air supply fan or a motorized louver, they must be interlocked with the boiler control panel to prove operation prior to burner ignition and during burner operation. Where manual louvers are used, ensure they are fully open prior to operating the boiler(s).

■ Combustion Air Ducted from the Outdoors

The combustion air supply may be ducted to the air inlet of the boiler.

Adhere to the following for installation:

- Adhere to the minimum air intake duct/piping diameters listed in **Table 1**.
 - An adapter (not supplied with boiler) may be required to connect the boiler air inlet to the combustion air ducting/piping. See **Figure 12**.
- **NOTE:** The weight of combustion air intake piping must not be supported by the boiler. Ensure air intake piping is externally supported on hangers or straps.
- The boiler room must not contain contaminated air.
 - The combustion air intake termination must be located as to not be subjected to the intake/exhaust effects of other mechanical equipment such as other fuel-fired heating equipment, loading docks, generators, air handling systems, and cooling towers.
 - Ensure the boiler room air is maintained at a dew point temperature below the temperature of the combustion air. Failure to provide adequate ventilation or control dew point temperature may result in water or ice build-up on the combustion air piping, leading to increased maintenance or damage to boiler components.
 - Insulating the combustion air intake duct is not recommended.



WARNING

All information in this manual is for reference and guidance purposes, and does not substitute for required professional training, conduct, and strict adherence to applicable jurisdictional/professional codes and regulations.



CAUTION

Ensure there is not a negative pressure in the boiler room. The boiler room pressure must be neutral relative to the outdoors.

Particulate matter or chemicals (example: chlorine, sulfur, fluorocarbon refrigerants, fluorine, perchlorethylene, halogenated compounds) in the combustion air supply to the boiler will cause damage or failure to the burner and heat exchanger. Damage due to air contamination is not covered under warranty.

The weight of the combustion air intake (CAI) ducting must not be supported by the boiler CAI connection. Failure to provide proper external support for CAI ducting may damage the blower.

WARNING

All information in this manual is for reference and guidance purposes, and does not substitute for required professional training, conduct, and strict adherence to applicable jurisdictional/professional codes and regulations.

Where using non-metallic flue gas vent materials ensure the maximum temperature of the material is not exceeded. Typical material ratings are 149°F (65°C) for PVC, 194°F (90°C) for CPVC, and 230°F (110°C) for Polypropylene. Verify ratings with your supplier to ensure material selections are appropriate for the application. Typical flue gas exhaust temperatures range from 0°F to 30°F (17°C) above return (boiler inlet) water temperature, this range may vary based on commissioning settings and site conditions.

Do not use insulation on non-metallic flue gas vent materials. Use of insulation may elevate pipe wall temperatures, resulting in the potential for vent material failure.

CAUTION

The use of rain caps on the flue gas exhaust termination is not recommended.

The flue gas exhaust vent must terminate a minimum of 4 feet (1.22 m) above the combustion air intake termination. Greater vertical separation is strongly recommended where possible.

- The air intake system must be designed to prevent any moisture from draining to the boiler. Slope the air intake duct down away from the boiler. See **Figure 17**.

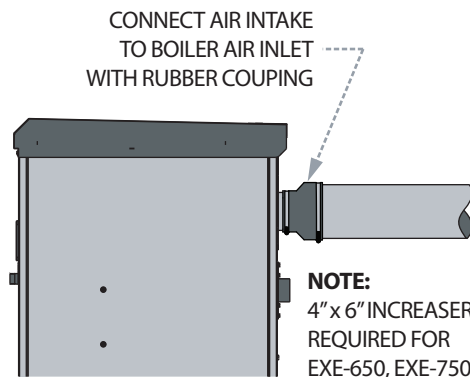

FIGURE 12 - CONNECTING TO BOILER AIR INLET

- Air Intake pipes and fittings shall be Schedule 40 PVC pipe or smooth-walled galvanized steel. All Schedule 40 PVC pipe, fittings, primer and cement must conform to American National Standard Institute and the American Society for Testing and Materials (ANSI/ASTM standards) per pipe manufacturer's requirements.
- Intake PVC piping must be assembled using cement. This will ensure that the intake is air tight and will not allow contaminants from the boiler room into the boiler. The cement must be free flowing and contain no lumps, undissolved particles or any foreign matter that adversely affects the joint strength or chemical resistance of the cement. The cement must not show gelation, stratification, or separation that cannot be removed by stirring.
- Adhere to procedure for cementing joints (per ASTM D2855).
- Avoid sidewall exhaust with roof terminated intake air. This may lead to reverse stack effect when the boiler is idle.

Flue Gas Exhaust Venting

This boiler is equipped with a vent connection at the lower rear of the boiler.

Adhere to National Fuel Gas Code (ANSI Z223.1) and the following for installation:

- This boiler is a Category II/IV appliance, thus requiring special gas vent material appropriate for condensing, positive pressure applications. Any venting material supplied for the boiler must be AL29-4C or 316L/444 SS, listed and labeled to UL 1738, and guaranteed appropriate for the application by the manufacturer and supplier of the venting. It is also acceptable to vent as Category II condensing, negative pressure, for which an upsized diameter is typically required.
- Where allowed by the authority having jurisdiction (AHJ), the exhaust may be vented using Schedule 40 PVC, Schedule 40 CPVC, or Polypropylene listed and labeled to UL 1738 or ULC S636. If venting with Schedule 40 PVC, at minimum the first 8 inches of pipe must be Schedule 40 CPVC. Do not insulate plastic exhaust vents. Canada only: Schedule 40 PVC, CPVC, or Polypropylene vent materials must be listed and labeled to ULC S636.
- The use of cellular core PVC/CPVC or Radel® (polyphenylsulfone) in venting systems is prohibited.

4. Do not use boot tees or bullhead tees. Use inline condensate drains in place of boot tees at the bottom of a vertical rise.
5. Barometric dampers are physically open to the mechanical space. When used in a condensing boiler application with negative pressure (Category II) exhaust vent, the design must prevent flue gas condensate from draining down the outside of the stack or dripping into the space. For installation using a barometric damper, verify the air openings meet the requirements in **Table 6**, and a spill switch and a Carbon Monoxide detector are installed and interlocked with the boiler(s). Barometric dampers must never be used in a positive pressure (Category IV) exhaust or ducted combustion air application.
6. A stainless steel adapter (not supplied) specific to vent manufacturer type and material will be required. Refer to **Table 7** or consult the venting supplier for guidance.

TABLE 7 - FLUE GAS VENT ADAPTERS

Manufacturer & Type	Material	Part/Catalog Number	
		EXE-399/500	EXE-650/750
Centrotherm InnoFlue	Polypropylene	ISAEXE04	ISAEXE06
DuraVent FasnSeal	316 SS	FSAAU4B	FSAAU6B
HeatFab Saf-T Vent EZ Seal	316 SS	5401BOI	5601BOI
HeatFab Saf-T Vent CI PLUS	AL29-4C	CCA04ADUV	CCA06ADUV
Jeremias SWGV/DWGV	444	SWGV4-FULEXE	SWGV6-FULEXE
Metal-Fab Corr/Guard	AL29-4C	4CGIA2	6FCSSBA
Various	PVC/CPVC	4-50-420649	4-50-420648
Z-Flex Z-Vent	AL29-4C	2SVSAEDRXE04	2SVSAEDRXE06

7. Adequate provision must be made to support the weight of the exhaust venting. It must not be supported by the boiler exhaust connection.
8. Following the venting manufacturer's instructions for installation of flue gas venting.
9. Horizontal runs must allow for flue gas condensate to drain back with a minimum upward pitch of ¼" (7 mm) per foot (300 mm) run. Failure to do so can create a condensate pocket, which can result in an inoperative boiler. There must be no low spots in the exhaust vent, as this can also result in a condensate pocket.
10. The boiler control will automatically disable the burner should the flue gas temperature exceed the vent material limit setting. To prevent the likelihood of approaching venting material limitations, it is suggested to use AL 29-4C, 316L, or Polypropylene flue gas vent in applications where return water temperatures will exceed 140°F.
11. If stack drains are installed, they must be installed per the requirements of the flue gas vent manufacturer and pitched back to the drain, minimum pitch of ¼" (7 mm) per foot (300 mm) run.

 **WARNING**

Fulton accepts no liability for installation of any venting, including the selection of venting materials. Maximum allowable flue gas operating temperatures may vary by manufacturer. Consult the venting supplier for maximum allowable temperatures.

Vent connectors serving appliances vented by natural draft shall not be connected into any portion of mechanical draft systems operating under positive pressure.

Where using non-metallic flue gas vent materials ensure the maximum temperature of the material is not exceeded. Typical material ratings are 149°F (65°C) for PVC, 194°F (90°C) for CPVC, and 230°F (110°C) for Polypropylene. Verify ratings with your supplier to ensure material selections are appropriate for the application. Typical flue gas exhaust temperatures range from 0°F to 30°F (17°C) above return (boiler inlet) water temperature, this range may vary based on commissioning settings and site conditions.

Do not use insulation on non-metallic flue gas vent materials. Use of insulation may elevate pipe wall temperatures, resulting in the potential for vent material failure.

 **CAUTION**

The use of rain caps on the flue gas exhaust termination is not recommended.

The flue gas exhaust vent must terminate a minimum of 4 feet (1.22 m) above the combustion air intake termination. Greater vertical separation is strongly recommended where possible.

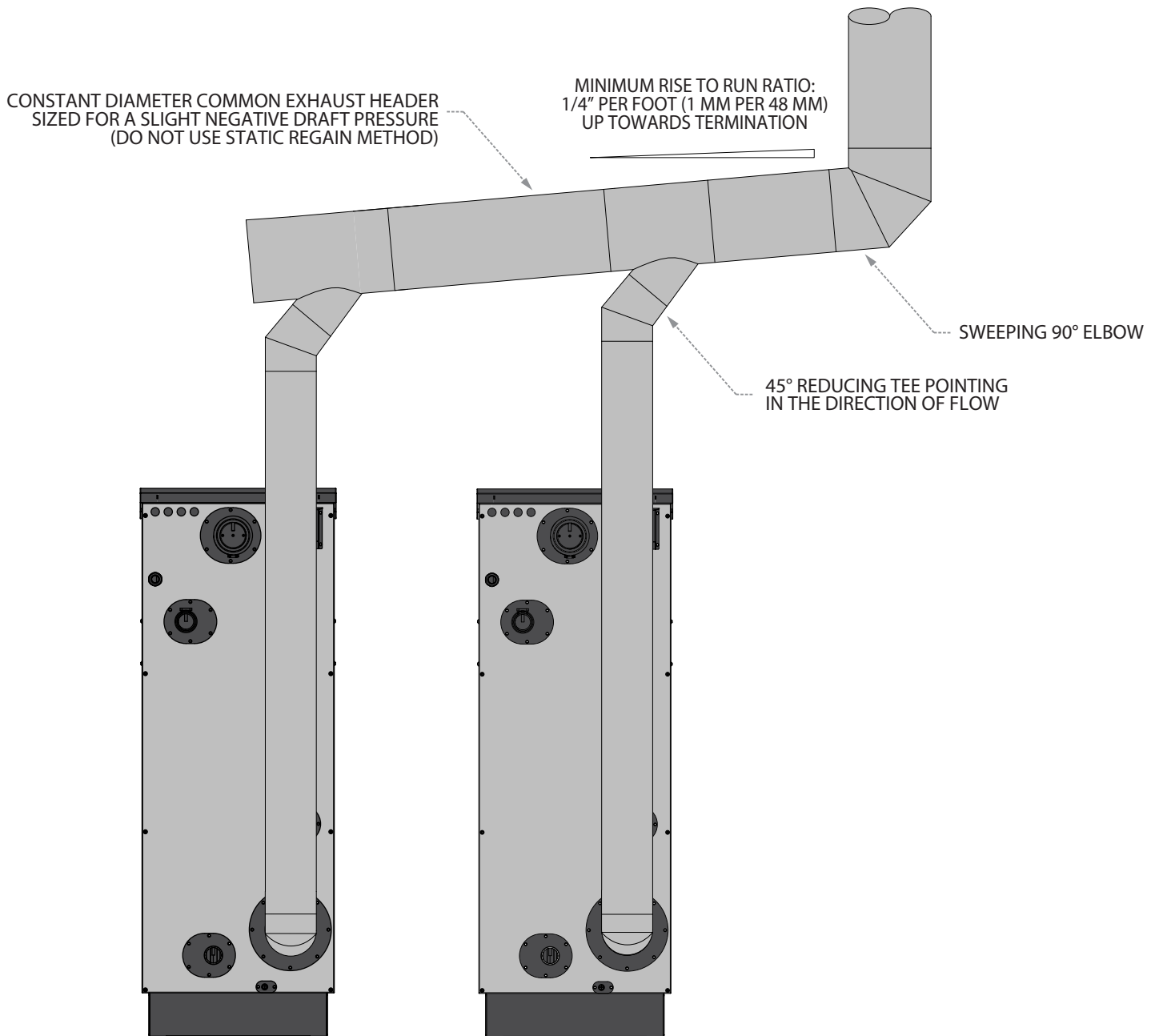

FIGURE 13 - COMMON EXHAUST VENTING; TYPICAL INSTALLATION GUIDELINES

Common Flue Gas Venting Layouts

It is possible to combine the air intake and/or exhaust venting of multiple boilers. The pressure drop across the entire common system, the combined total of both air intake and exhaust, must comply with the draft pressure requirements for an individual boiler, see **Table 4**.

Refer to **Figure 13** and adhere to the following for installation:

1. Consult your venting supplier for guidance in designing common vented installations. The system must be thoroughly evaluated by a professional using accepted engineering practices to prevent backflow of exhaust gases through idle boilers.
2. This boiler is not approved for common venting with other equipment, such as steam boilers, water heaters, generators, and other types of equipment.
3. The AHJ may require the installation of a CO detector interlocked with the boiler(s), this is recommended best practice even where not required.
4. A constant diameter common header is recommended. Do not use the static regain method.
5. A minimum 1/4" rise per foot run is required for horizontal sections.
6. Where individual stacks transition into the common header, a 45 degree reducing tee or elbow in the direction of flow is recommended. Straight-in or 90 degree tees must not be used.
7. Precautions must be taken to ensure that the draft pressure at each boiler is maintained within in the required range (refer to **Table 4**) throughout all conditions while also maintaining a slight negative draft pressure in the common exhaust header. Consider all possible operating conditions of the exhaust system specific to the application, including:
 - Low and high flue gas temperatures
 - Low and high ambient air temperatures
 - All boilers operating at their maximum input rating capacity
 - One boiler in the system operating at the low fire position
 - No boilers on, pre-purge and ignition
8. Consider the natural draft effects associated with vertical exhaust vent rise. Over-draft control accessories, such as modulating stainless steel dampers, may be required to mitigate a negative pressure exceeding the value in **Table 4**. An undersized common exhaust vent or pressure drop due to the horizontal run can create a positive pressure common exhaust situation which may require a mechanical draft assist (exhaust fan) system.

When designing a draft system for a quantity of two or more boilers, the following items must be considered and addressed by the parties responsible for designing and providing that system:



WARNING

Fulton accepts no liability for installation of any venting, including the selection of venting materials. Maximum allowable flue gas operating temperatures may vary by manufacturer. Consult the venting supplier for maximum allowable temperatures.

Vent connectors serving appliances vented by natural draft shall not be connected into any portion of mechanical draft systems operating under positive pressure.

WARNING

Fulton accepts no liability for installation of any venting, including the selection of venting materials. Maximum allowable flue gas operating temperatures may vary by manufacturer. Consult the venting supplier for maximum allowable temperatures.

CAUTION

The use of rain caps on the flue gas exhaust termination is not recommended.

The flue gas exhaust vent must terminate a minimum of 4 feet (1.22 m) above the combustion air intake termination. Greater vertical separation is strongly recommended where possible.

■ Common Venting Exhaust Backflow Prevention

1. When combining the exhaust vents of multiple boilers, the system must be designed to guarantee flue gas and exhaust will not backflow through an idle boiler. This requires appropriately sizing a Category II common exhaust vent to maintain a slight negative draft pressure of -0.01 to -0.04"wc throughout all operating conditions when one or more boilers are idle.
2. It is recommended to install individually piped intake vents or use neutral pressure boiler room air with a common exhaust system. For common exhaust vent applications also combining combustion air intake (CAI) ducts into a common duct, it is necessary to upsize the common CAI duct for a negligible pressure loss.
3. If the common exhaust configuration does not allow for a stable negative pressure under all operating conditions then a mechanical draft assist system, such as a variable speed exhaust fan, may be required.

Venting Terminations

Adhere to National Fuel Gas Code (ANSI Z223.1) and the following for installation:

1. Do not terminate the venting in an enclosed area. Care must be taken when selecting the type and orientation of the terminations.
2. All vent pipes and fittings must be installed with appropriate air space clearances to combustibles. These air space clearances apply to indoor or outdoor vents—whether they are open, enclosed, horizontal or vertical or pass through floors, walls, roofs, or framed spaces. The air space clearances should be observed to joists, studs, sub floors, plywood, drywall or plaster enclosures, insulating sheathing, rafters, roofing, and any other material classed as combustible.
3. To prevent the possible re-circulation of flue gases, the vent designer must take into consideration such things as prevailing winds, eddy zones, building configurations, etc. Adverse conditions effect operation reliability and durability of the boiler(s).
4. The required minimum air space clearances also apply to electrical wires and any kind of building insulation.
5. Listed termination parts must be used.
6. Select the air intake point of penetration where a minimum of 1/4" per foot (1 mm per 48 mm) upward pitch can be maintained.
7. It is recommended to install a mesh bird screen, with minimum 1/2" by 1/2" openings, at the combustion air intake termination. Climates subject to extreme cold may require alternate configurations to provide an increased surface area, such a cylindrical basket screens. Consult your venting supplier for recommendations.
8. It is important to locate the exhaust termination in such a way that it does not become blocked due to snow, ice, and other natural or man-made obstructions. If terminating into a prevailing wind, direct upward. Avoid areas (example: courtyards) where swirling high winds may be present.

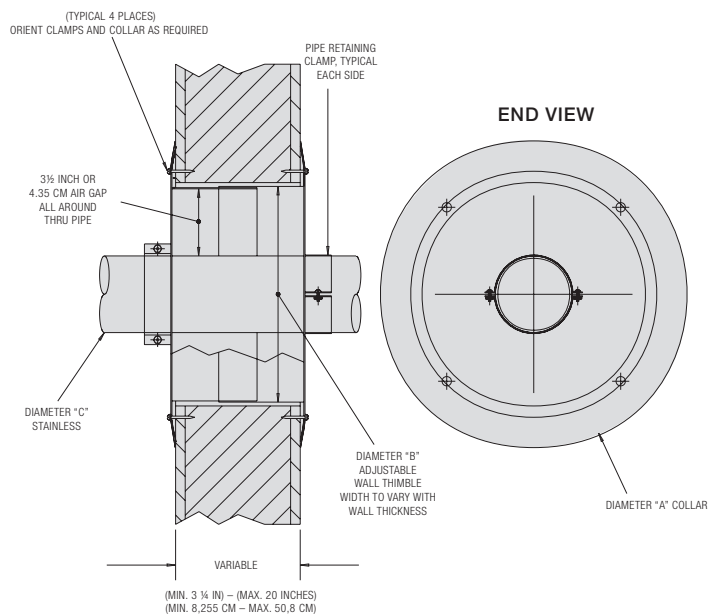

FIGURE 14 - WALL THIMBLE INSTALLATION

■ Wall Thimble Installation

Adhere to the following for installation (see **Figure 14**):

1. Insert the thimble through the wall from the outside.
2. Secure the outside flange to the wall with nails or screws, and seal with adhesive material.
3. Install the inside flange to the inside wall, secure with nails or screws, and seal with adhesive material.
4. Pass the vent pipe through the thimble from the outside and join to the rest of the vent system. Seal the pipe to the thimble flange with adhesive material.
5. Install two pipe retaining clamps around the intake as well as vent pipes on both ends of the wall thimble (on the inside and outside of the wall) through which intake and vent pipes are passed. They will prevent the intake and vent pipes from being pushed or pulled.

■ Roof Vent Termination

Adhere to the following for installation (see **Figure 13** and **14**):

1. The minimum vent height should extend at least 3 feet (0.9 m) above the roof, or at least 2 feet (0.6 m) above the highest part of any structure within 10 feet of the vent.
2. When installing inlet and exhaust terminations above the roof, the exhaust outlet must be installed 4 feet (1.22 m) minimum above and 4 feet (1.22 m)

minimum downwind from air supply inlet to prevent exhaust recirculation. Greater separation is strongly recommended.

3. The use of rain caps on the flue gas exhaust termination is not recommended. Rain caps contribute to ice buildup, stagnant vapor plumes, flue gas recirculation (FGR) and excess vent restriction. See **Figure 16** and **17**.

■ Side Wall Vent Termination

Adhere to the following for installation (see **Figure 17**):

► **NOTE:** The vent termination is joined to the vent pipe outside the wall. Use the same joining procedures for vent pipe and fittings.

1. When penetrating a non-combustible wall, the hole through the wall must be large enough to maintain the pitch of the vent and provide sealing. Use adhesive material to seal around the vent on both sides of the wall. When penetrating a combustible wall, a wall thimble must be used.
2. High-wind areas may require special termination consideration.
3. The termination of the vent system must be at least 12 inches (30.48 cm) above the finished grade, or at least 12 inches (30.48 cm) above normal snow accumulation level (for applicable geographical areas).
4. The termination of the vent system shall not be located over traffic areas such as public walkways, or over an area where condensate or vapor could create a nuisance or hazard.
5. Do not terminate below operable windows and building openings unless exception is granted by the authority having jurisdiction.
6. The vent terminations must be at least 4 ft (1.22 m) horizontally from electric meters, gas meters, regulators, and relief equipment.
7. When installing combustion air intake and exhaust terminations on the same wall, the exhaust outlet must be installed 4 feet (1.22 m) minimum above and 10 feet (3.05 m) minimum downwind from air supply inlet to prevent flue gas recirculation. Greater separation is strongly recommended.
8. Under certain wind conditions, some building materials may be affected by flue products expelled in close proximity to unprotected surfaces. Sealing or shielding of the exposed surfaces with a corrosion resistant material (such as an aluminum sheet) may be required to prevent staining or deterioration. Flue should be directed away from surfaces, if possible.

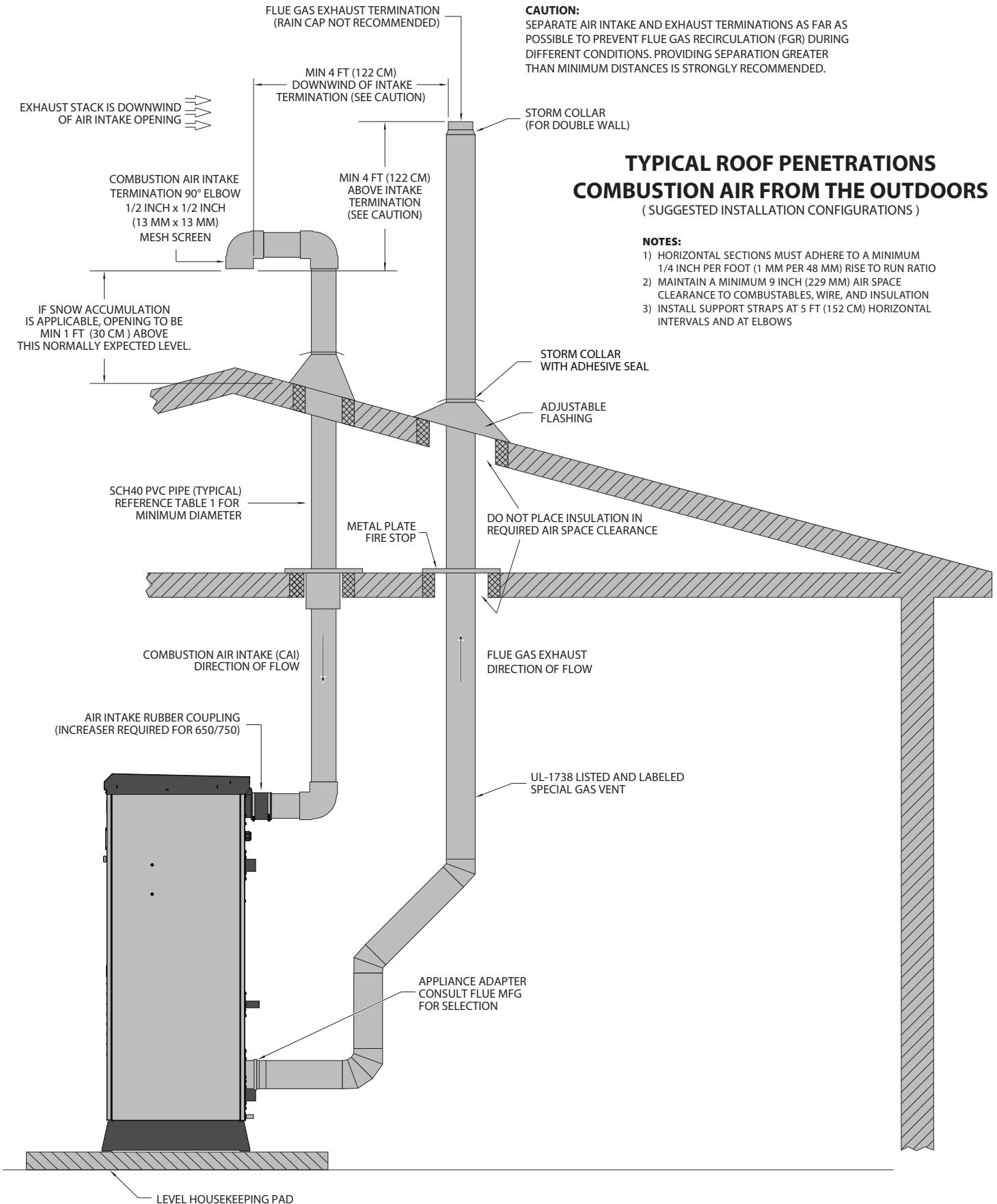

CAUTION:
SEPARATE AIR INTAKE AND EXHAUST TERMINATIONS AS FAR AS POSSIBLE TO PREVENT FLUE GAS RECIRCULATION (FGR) DURING DIFFERENT CONDITIONS. PROVIDING SEPARATION GREATER THAN MINIMUM DISTANCES IS STRONGLY RECOMMENDED.

FIGURE 15 - ROOF PENETRATION DETAILS

**TYPICAL ROOF PENETRATION
COMBUSTION AIR FROM THE ROOM**
(SUGGESTED INSTALLATION CONFIGURATIONS)

NOTES:

- 1) HORIZONTAL SECTIONS MUST ADHERE TO A MINIMUM 1/4 INCH PER FOOT (1 MM PER 48 MM) RISE TO RUN RATIO
- 2) MAINTAIN A MINIMUM 9 INCH (229 MM) AIR SPACE CLEARANCE TO COMBUSTIBLES, WIRE, AND INSULATION
- 3) INSTALL SUPPORT STRAPS AT 5 FT (152 CM) HORIZONTAL INTERVALS AND AT ELBOWS

CAUTION:

- 1) ADEQUATE COMBUSTION AIR AND VENTILATION MUST BE SUPPLIED TO THE BOILER ROOM IN ACCORDANCE WITH LOCAL CODES AND NFPA54/ANSI Z233.1, SECTION 9.3, AIR FOR COMBUSTION AND VENTILATION, CSA-B149.1 FOR CANADA.
- 2) THE MINIMUM NET FREE AREA REQUIREMENTS IN TABLE 6 MAY NOT SUPERSEDE LOCAL AND JURISDICTIONAL CODES AND REGULATIONS REQUIRING A GREATER NET FREE AREA. THE MORE STRINGENT OF THE TWO SHALL PREVAIL.

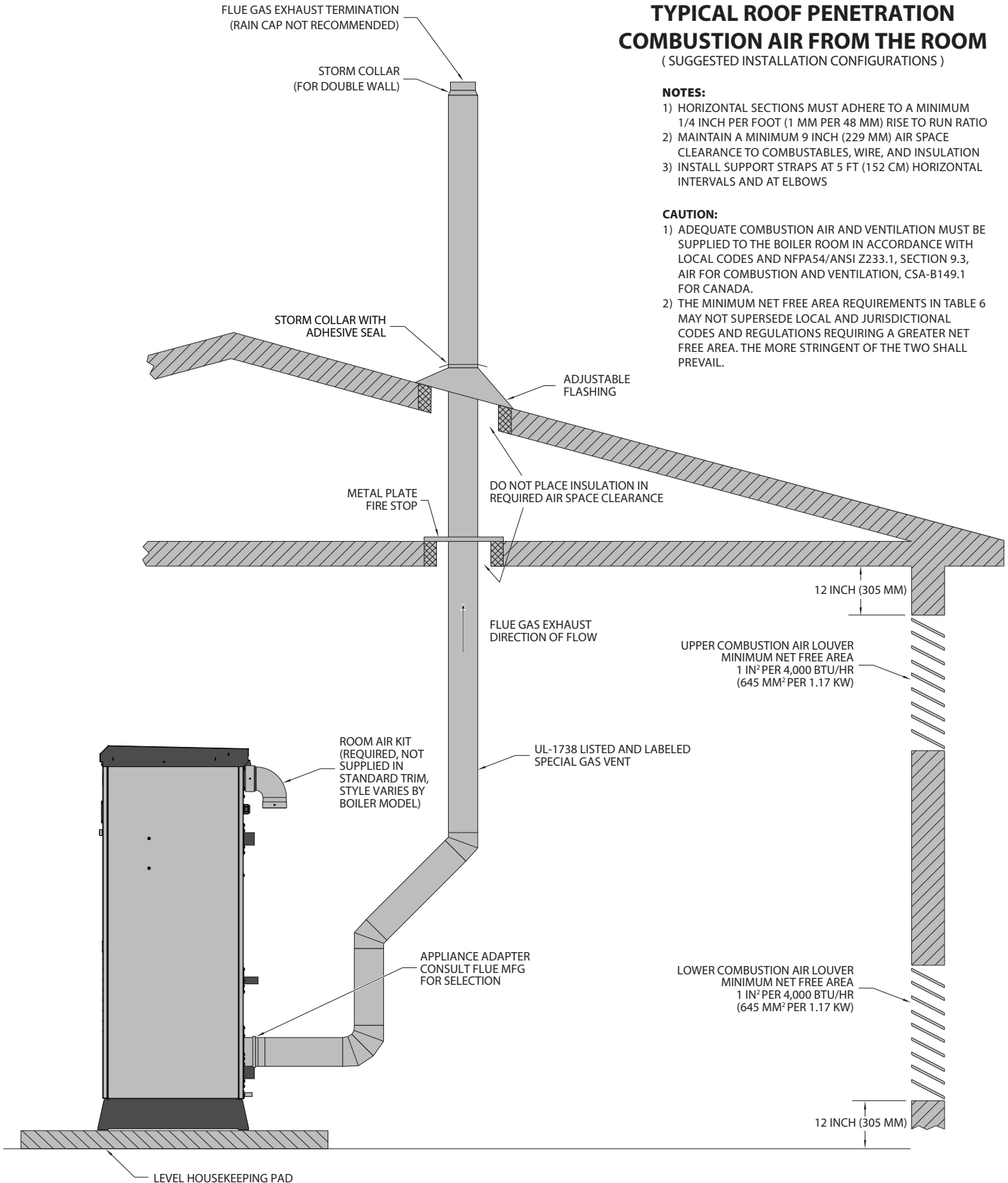

FIGURE 16 - ROOF PENETRATION WITH COMBUSTION AIR LOUVERS DETAILS

TYPICAL SIDE WALL PENETRATIONS

(SUGGESTED INSTALLATION CONFIGURATIONS)

NOTES:

- 1) HORIZONTAL SECTIONS MUST ADHERE TO A MINIMUM 1/4 INCH PER FOOT (1 MM PER 48 MM) RISE TO RUN RATIO
- 2) MAINTAIN A MINIMUM 9 INCH (229 MM) AIR SPACE CLEARANCE TO COMBUSTIBLES, WIRE, AND INSULATION
- 3) INSTALL SUPPORT STRAPS AT 5 FT (152 CM) HORIZONTAL INTERVALS AND AT ELBOWS

CAUTION:

SEPARATE AIR INTAKE AND EXHAUST TERMINATIONS AS FAR AS POSSIBLE TO PREVENT FLUE GAS RECIRCULATION (FGR) DURING DIFFERENT WIND CONDITIONS.

WALL TERMINATIONS DETAIL VIEW

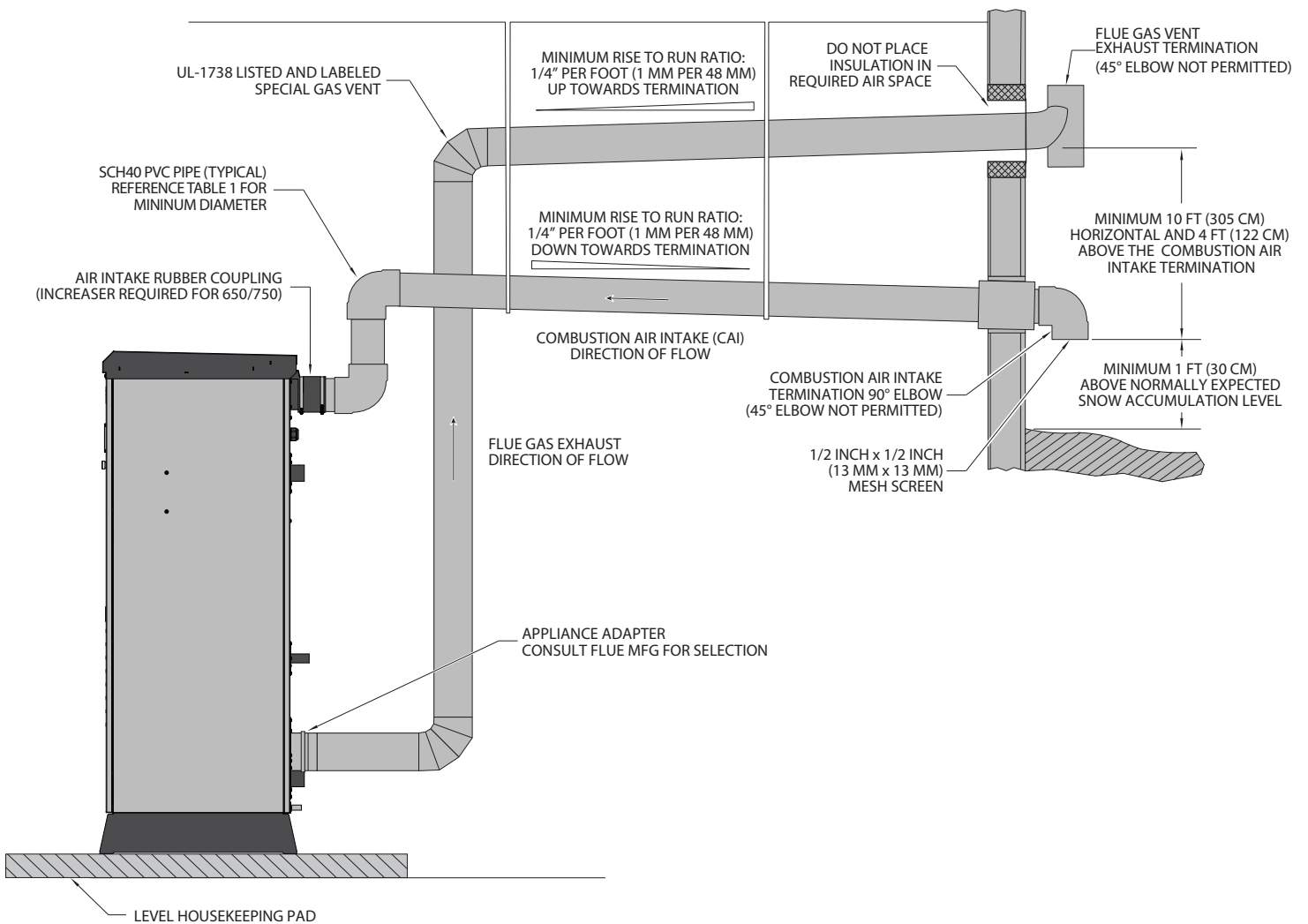
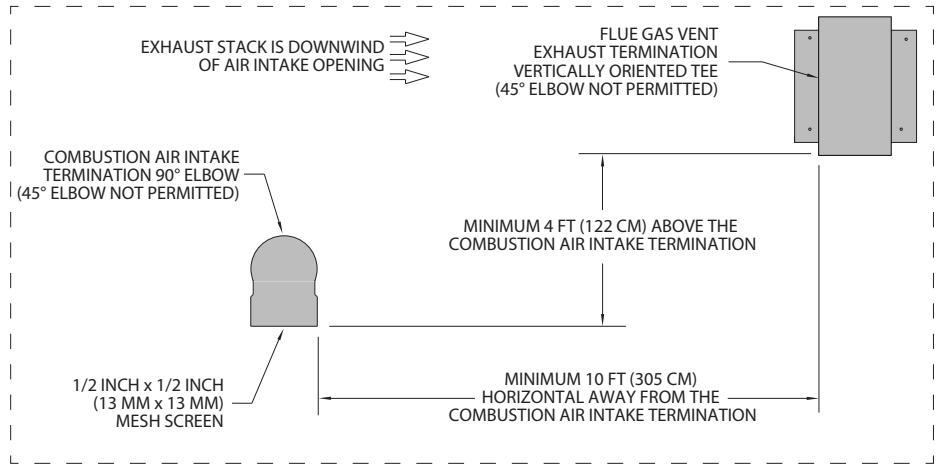

FIGURE 17 - SIDEWALL PENETRATIONS DETAILS

9. The flue gas vent termination must be a vertically oriented tee. A 45° elbow termination is not permitted.
10. The combustion air intake termination must be a downward facing 90° elbow. A 45° elbow termination is not permitted.

Removing an Existing Boiler

When an existing boiler is removed from a common venting system, the common venting system is likely to be too large for proper venting of the appliances remaining connected to it.

At the time of removal of an existing boiler, while the other appliances remaining connected to the common venting system are not in operation, the following steps should be followed with each appliance remaining connected to the common venting system placed in operation:

1. Seal any unused openings in the common venting system.
2. Visually inspect the venting system for proper size and horizontal pitch and determine that there is no blockage or restriction, leakage, corrosion or other deficiency, which could cause an unsafe condition.
3. Insofar as is practical, close all building doors and windows and all doors between the space in which the appliances remaining connected to the common venting system are located and other spaces of the building. Turn on clothes dryers and any appliances not connected to the common venting system. Turn on any exhaust fans, such as range hoods and bathroom exhausts, so they will operate at maximum speed. Do not operate a summer exhaust fan. Close fireplace dampers.
4. Place the appliance being inspected in operation. Follow the lighting instructions. Adjust the thermostat so that the appliance will operate continuously.
5. Test for spillage at the draft hood relief opening after 5 minutes of main burner operation. Do not use the flame of a match or candle or smoke from a cigarette, cigar or pipe.
6. After it has been determined that each appliance remaining connected to the common venting system properly vents when tested as outlined above, return doors, windows, exhaust fans, fireplace dampers and any other gas-burning appliance to their previous conditions of use.

7. Any improper operation of the common venting system should be corrected so the installation conforms with the National Fuel Gas Code, ANSI Z223.1. When resizing any portion of the common venting system, the common vent system should be resized to approach the minimum size as determined using the appropriate tables.

Assembly of Fulton Multi-Skid Systems

Adhere to the following for multi-skid engineered systems:

1. Refer to the Fulton mechanical/electrical drawings during assembly.
2. Ensure that equipment orientation allows for operation interface and maintenance.
3. Align the skids as shown on the drawings ensuring that skid fasteners (skid joint angles) are matched. The skid joint angles are a matched set and the edges of the fasteners should be exactly aligned.

► *NOTE: Do not bolt the skids to the housekeeping pad/floor until all of the piping has been reassembled and tightened.*

4. Ensure the skids are level and flat before fastening the skids together with the supplied bolts. The skids should be leveled front to back, side to side and corner to corner. Failure to properly level the skids will result in piping misalignment. A level or laser level should be used to verify skid alignment (when a standard level is used, the length should be appropriate for the skid). If assembling multi-component support stands, attach sections using the supplied bolts through the tank frame mounting plates. These should be hand tight until all of the piping is assembled.

► *NOTE: Note: skids are leveled at the factory using a laser level.*

5. Connect the piping between the skids by matching the union connections and/or flange stamps and tightening. Refer to the mechanical drawing as necessary to confirm location of spool pieces etc. as the flange stamps are shown on the drawing in hexagonal callouts. The flange stamps should be matched and aligned (the flange stamps should be directly across from one another. Rotating a flange will result in piping misalignment). Bolts should be hand tight until all of the piping is assembled. Refer to the appropriate instructions to tighten the flanges to the required torque specifications. Support pipe runs as required.

6. Ensure that a low point drain is installed in the piping.
7. Connect the conduit runs between the skids and tighten conduit connectors.
8. Locate the supplied wiring for the equipment and pull wiring through the appropriate conduit runs. Electrical wires are labeled for easy landing. Connect all wiring per the Fulton supplied electrical drawings.
9. If a header sensor is supplied, mount the header sensor as shown in the mechanical drawing.

► *NOTE: For piping supplied in sections, make up and connect hand tight until all sections are in place to ensure sections align properly. Sections are match marked for reassembly.*

10. Tighten all connections, including threaded and flanged factory connections which may loosen during shipment.
11. Pneumatically test the piping (at 15 psig [103 kPa] maximum) prior to filling the systems.
12. Check bolts and connections for tightness after the first heat up cycle. Retorquing may be required.

Electrical Connections and Devices

The boiler is designed to operate within the following limits at the connection terminals:

- AC power supplied is within +/- 5% of the boiler rated voltage with the rated frequency applied; or AC power supplied is within +/- 5% of the rated frequency and with the rated voltage; or a combined variation in voltage and frequency of +/-5% (sum of absolute values) of rated values.

► *NOTE: Operating outside requirements may de-rate the boiler and/or damage electrical components. There is no warranty on components that fail due to improper electrical service.*

Full Load Amps (FLA) is the measured amperage for the boiler at its maximum operating condition at rated voltage. The type of breaker/fusing selected, in combination with the FLA, will affect proper circuit sizing/protection. Please refer to your state's adoption of NEC or the authority having jurisdiction for proper sizing/selection.

A strain relief is provided on the back of the boiler for mains "line" voltage wiring.

Knockouts are provided for low voltage and communication wiring. Do not run Building Management System (BMS) or any other communication wiring into the high voltage strain relief.

The boiler's cabinet features removable panels to facilitate maintenance access. Do not run conduit through or over these access panels.

Adhere to the following when making electrical connections:

1. Install wiring in accordance with NEC Sec. 110.3(B) or CSA C22.1 for Canada for a maximum recommended branch circuit voltage drop of 3% and a maximum total voltage drop for a combination of both branch circuit and feeder not to exceed 5%.
2. Install wiring and ground in boiler in accordance with authority having jurisdiction or in absence of such requirements National Electrical Code, ANSI/NFPA 70.
3. Connect power to the boiler using connectors rated for the minimum in **Table 1**, and are compliant with local electrical codes.
4. A reference schematic excerpt is shown in **Figure 18**. Reference field connection locations are shown in **Figure 19**. Always refer to the electrical drawing provided with the boiler for the full as-built schematic diagram.

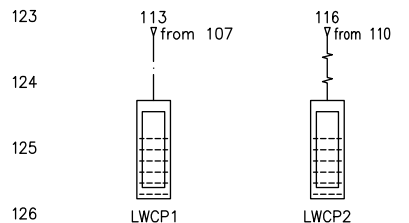
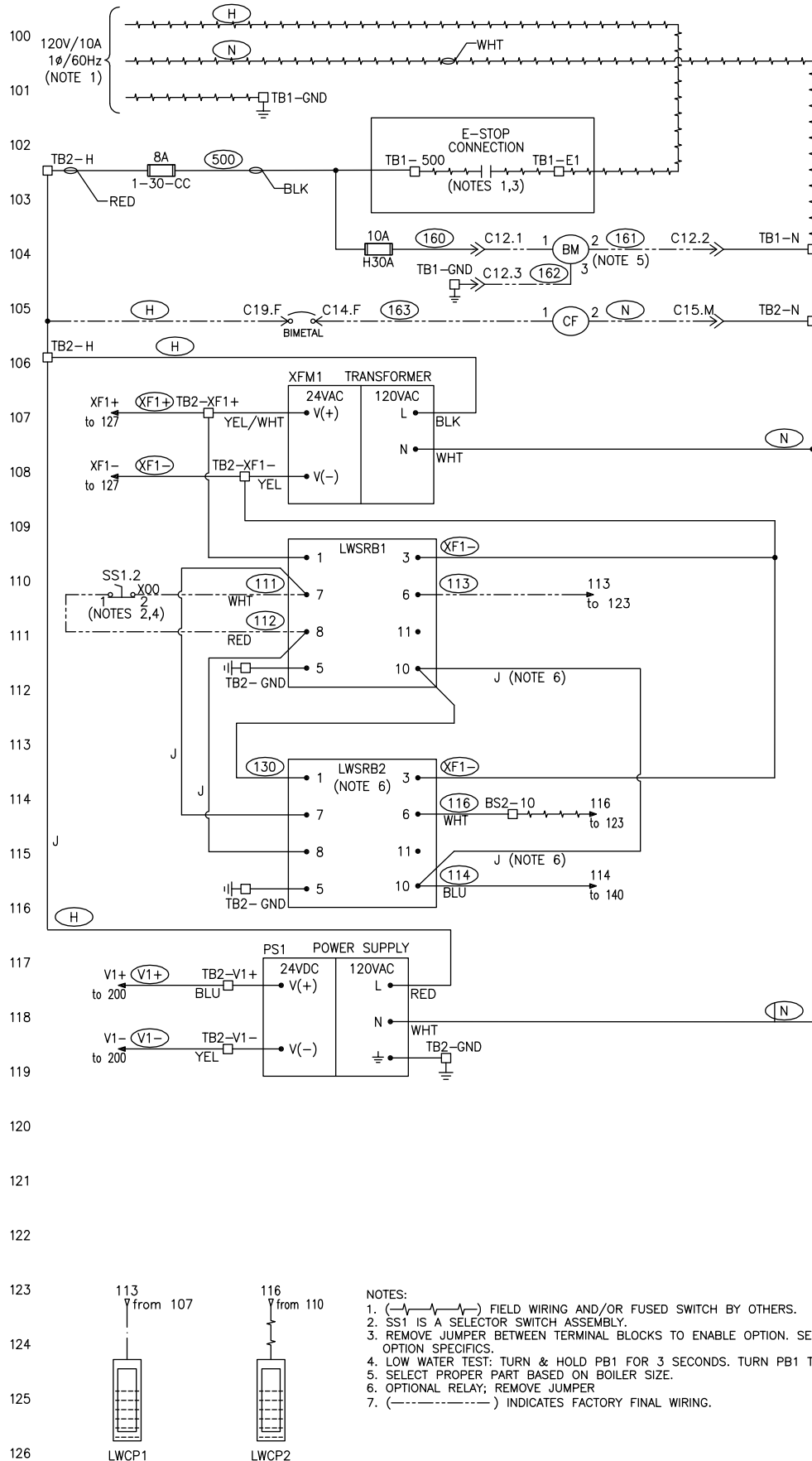
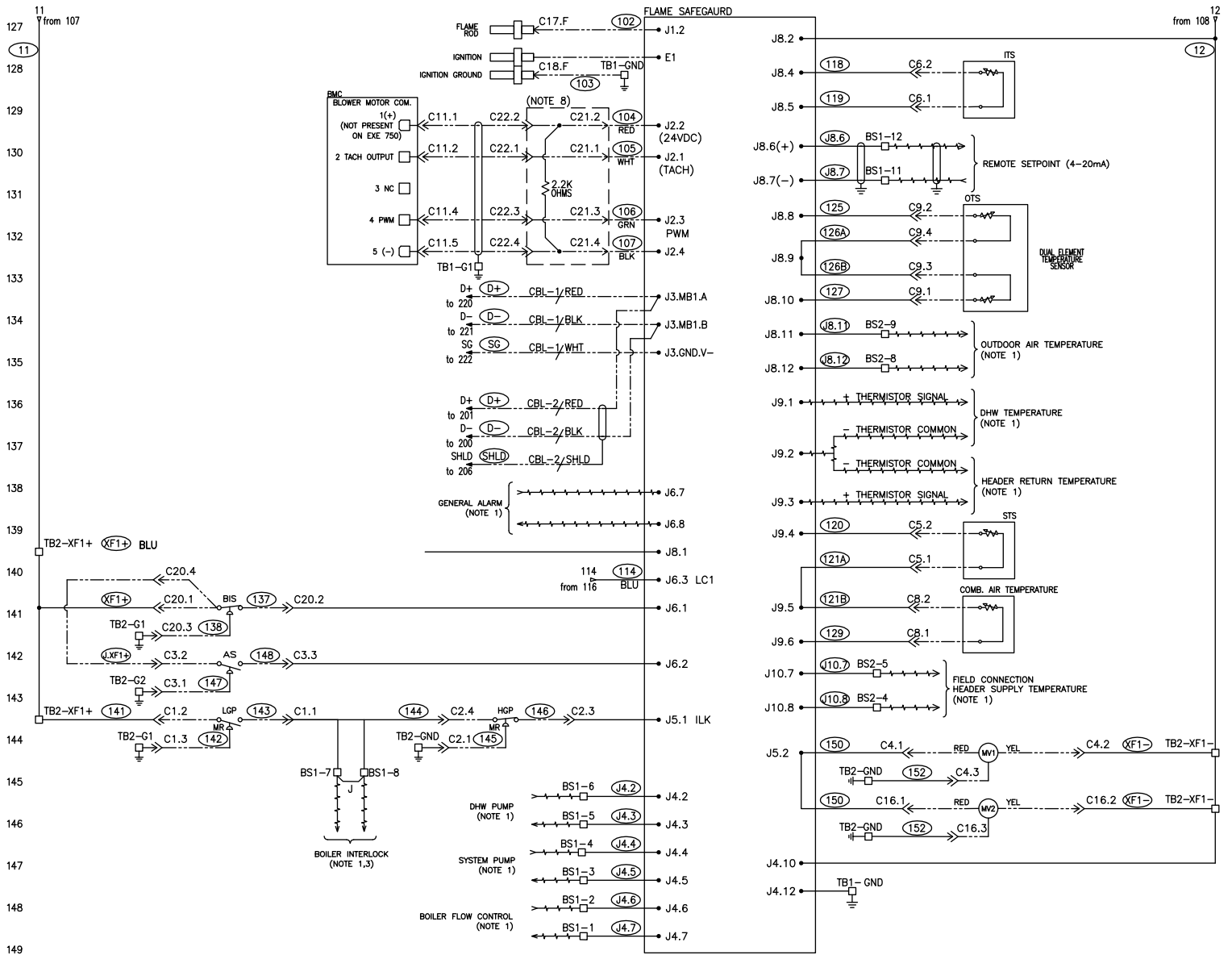

FIGURE 18 - ELECTRICAL SCHEMATIC DIAGRAM (REFERENCE ONLY)



CONNECTOR CHART	
CONNECTOR #	COMPONENT
C1	LOW GAS PRESSURE (LGP)
C2	HIGH GAS PRESSURE (HGP)
C3	AIR SWITCH (AS)
C4	MAIN VALVE 1 (MV1)
C5	STACK TEMPERATURE SENSOR (STS)
C6	INLET TEMPERATURE SENSOR (ITS)
C7	CONDENSATE FLOAT SWITCH (CFS)
C8	COMBUSTION AIR (COMB. AIR)
C9	OPERATING TEMPERATURE SENSOR (OTS)
C10	N/A
C11	BLOWER MOTOR COM. (BMC)
C12	BLOWER MOTOR POWER (BM)
C13	N/A
C14	(H) CONTROL FAN (CF)
C15	(N) CONTROL FAN (CF)
C16	MAIN VALVE 2 (MV2)
C17	FLAME ROD
C18	IGNITION GROUND
C19	(H) BIMETAL
C20	BLOCKED INTAKE SWITCH (BIS)
C21	EXE 650-750 BLOWER MOTOR COM. JUMP
C22	BLOWER MOTOR COM. (BMC)

- NOTES:
- (---) FIELD WIRING AND/OR FUSED SWITCH BY OTHERS.
 - SS1 IS A SELECTOR SWITCH ASSEMBLY.
 - REMOVE JUMPER BETWEEN TERMINAL BLOCKS TO ENABLE OPTION. SEE BOM FOR OPTION SPECIFICS.
 - LOW WATER TEST: TURN & HOLD PB1 FOR 3 SECONDS. TURN PB1 TO RESET.
 - SELECT PROPER PART BASED ON BOILER SIZE.
 - OPTIONAL RELAY; REMOVE JUMPER
 - (-----) INDICATES FACTORY FINAL WIRING.

FIGURE 18 (CONTINUED) - ELECTRICAL SCHEMATIC DIAGRAM (REFERENCE ONLY)

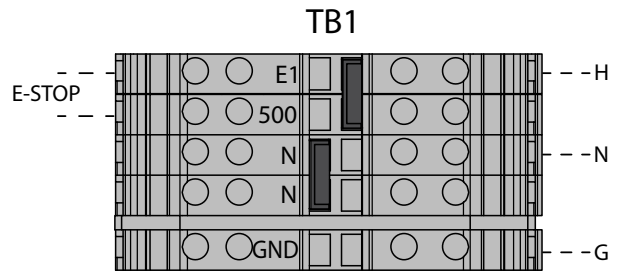
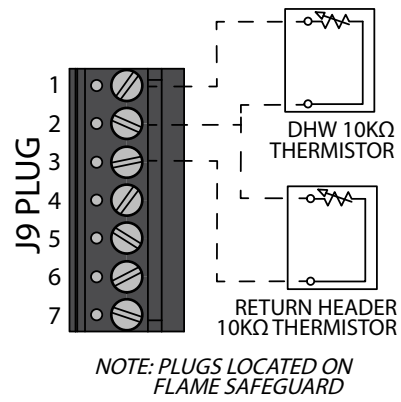
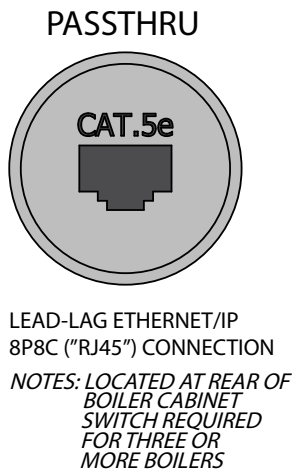
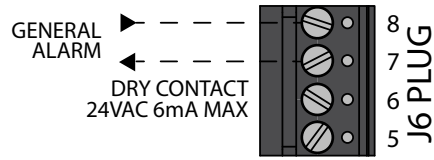
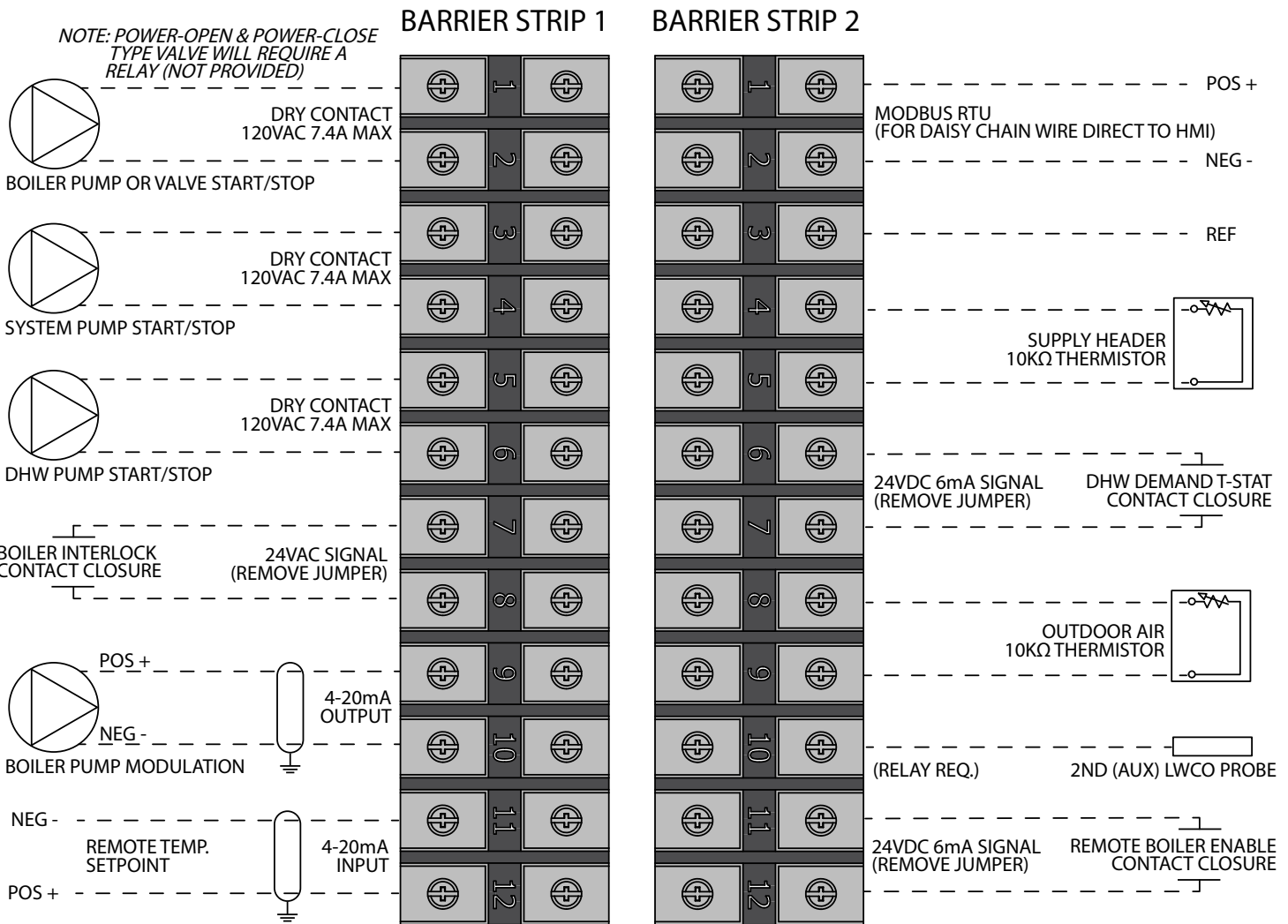

NOTES: LOCATED ON CONTROLS PANEL
120VAC 60HZ 1PH
E-STOP REQUIRES JUMPER REMOVAL
SIZE E-STOP CIRCUIT FOR FLA OF BOILER

FIGURE 19 - FIELD ELECTRICAL CONNECTIONS

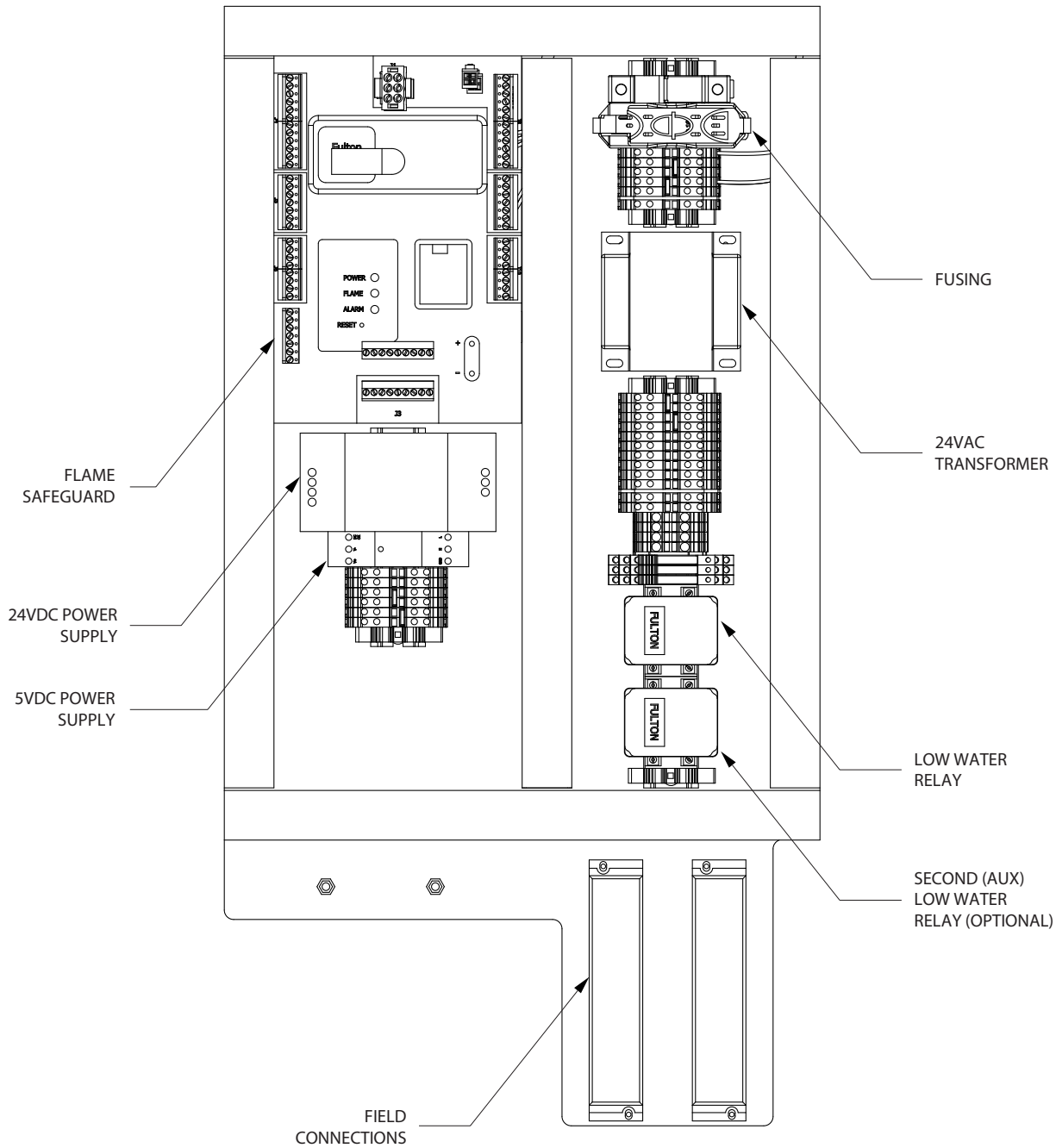

FIGURE 20 - ELECTRICAL CONTROLS LAYOUT (REFERNCE ONLY)

■ Locations for Field Wiring

Locations (Figure 21) are provided at the rear of the boiler for routing field wiring to the boiler control panel. Use only these locations, do not drill new conduit holes or route wiring through alternate paths. Do not run wiring directly through the removable or hinged panels doors.

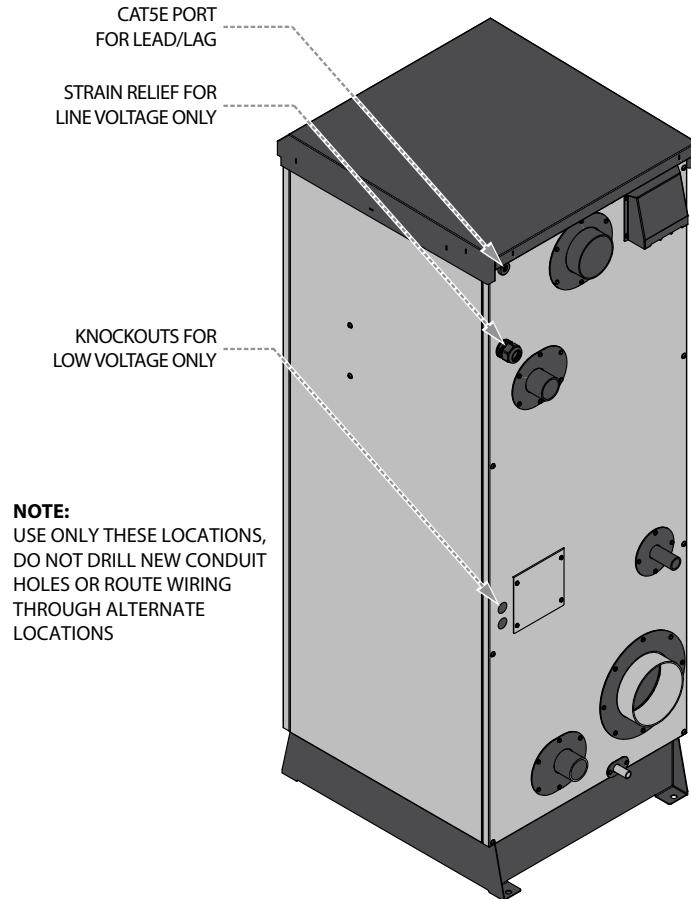

FIGURE 21 – LINE VOLTAGE AND LOW VOLTAGE LOCATIONS

■ Electrical and Controls Options

The electrical and controls options required and supplied will vary depending on the unique requirements and piping arrangements of the hydronic system. Refer to the separate **Technical Data Sheet** or **Manual** of each device for additional instructions. See **Electrical Schematic Diagrams** for locations of field wiring connections on the below electrical devices and controls options.

LEAD/LAG INTEGRATED SEQUENCING WIRING

1. The Fulton PURE Control™ includes integrated sequencing capabilities. When utilized, the boiler control system will automatically stage boilers and operate burner firing rates in parallel as necessary to maintain a hydronic setpoint.

2. The lead boiler and all lag boilers are rotated automatically.
3. The supply header temperature sensor is used as the Lead/Lag process variable and is required. Wire the sensor to a boiler "Supply Header" connection and install downstream of the boilers in the common supply water header for proper operation of the sequenced plant.
4. Additional devices and sensors may be required, and will vary by application.

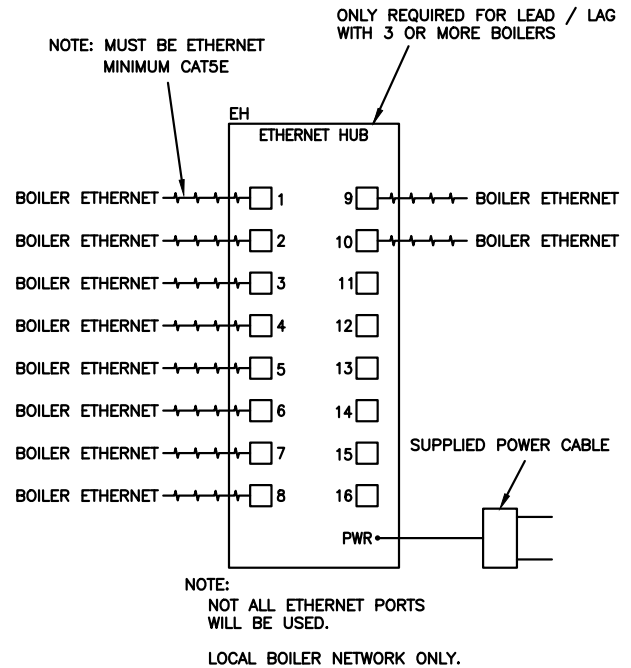

FIGURE 22 - ETHERNET-IP FIELD WIRING

5. Communication between the boilers is performed using an Ethernet/IP network field wired with Cat5e or Cat6 cabling. An 8P8C ("RJ45") female connector port is provided on the boiler. Two boilers may be directly connected. For installations of 3 to 10 boilers a 10/100 Ethernet switch is required.
6. Available as an option from the factory is a 16-port Ethernet switch with a 120VAC power adapter using a standard NEMA 1-15 plug, this device is intended for field installation in a clean dry area such as a networking closet, rack, or panel enclosure. For complete instructions, refer to the **Technical Data** sheet for 2-45-315010 prior to installation.

7. Also available as an alternative option from the factory is a 5-port 24VDC Ethernet switch that may be field DIN rail mounted inside of the boiler cabinet. For complete instructions, refer to the **Technical Data** sheet for 2-45-315044-31 prior to installation.
8. See the **Operation** section for information on programming this feature. Refer to the **Hydronic PURE Control™ User Manual** for complete instructions.

► INTEGRATION WITH THE MODSYNC SEQUENCING SYSTEM

Reference the Installation, Operation & Maintenance Manual and Electrical Schematic for the ModSync Sequencing System. Communication requires shielded three-wire twisted pair Belden 3106A or equivalent. Shield must be grounded at one end only and tied directly to Earth ground.

► SUPPLY HEADER TEMPERATURE SENSOR

1. A hydronic supply sensor and 1/2" NPT well is used for temperature control. This is a 2-wire 10k ohm thermistor.
2. This sensor is required for any multiple boiler installation utilizing the integrated sequencing (lead/lag) capabilities.
3. This sensor is required for single boiler installations with primary-secondary piping arrangements to monitor the secondary (system) loop.
4. The sensor monitors hydronic loop temperature in the common supply piping as a process variable for sequencing and modulation purposes. The control uses this information when comparing actual loop temperature to setpoint.
5. It is field installed downstream of the boilers in the common supply water header. The well must be directly in the path of flow and not isolated with a valve to provide an accurate temperature reading. Do not install the supply header temperature sensor in the return water header.
6. See **Figures 4 – 7** for the proper installation location in hydronic piping.
7. When extending the wire lead, use 18 to 22awg twisted 2 conductor stranded copper with insulated jacket. Ensure connections are tight with no shorts. Soldered and heat shrink tubing connections are recommended. Never use wire nuts to join lead to extension.

8. If the System Supply value becomes unavailable across the Universal Data system, boilers configured for Lead/Lag will lack a process variable and will automatically failsafe to local temperature control operation. For added redundancy, one or more additional header sensors may be wired to additional boilers in the Lead/Lag plant and configured as Local Network Providers of System Supply.
9. For complete instructions, refer to the **Technical Data** sheet for the supply header sensor prior to installation.

► OUTDOOR AIR TEMPERATURE SENSOR KIT

1. If outdoor air temperature reset capabilities are to be utilized, an outdoor air temperature sensor kit is required and field wired to a boiler. This is a 2-wire 10k ohm thermistor.
2. An outdoor air temperature sensor kit is not required if using fixed water temperature operation, or if the boiler control is receiving an external hydronic setpoint signal over a communication protocol or analog signal.
3. The sensor must be installed on a north facing exterior wall, in a location that will not be exposed to direct sunlight or influenced by other mechanical equipment.
4. Mount in the vertical position, sensor sheath pointing downward.
5. When extending the wire lead, use 18 to 22awg twisted 2 conductor stranded copper with insulated jacket. Ensure connections are tight with no shorts. Soldered and heat shrink tubing connections are recommended. Never use wire nuts to join lead to extension.
6. For complete instructions, refer to the **Technical Data** sheet for the outdoor air temperature sensor prior to installation.

► DOMESTIC HOT WATER (DHW) TEMPERATURE SENSOR

1. This boiler is capable of providing indirect domestic hot water through a heat exchanger. A domestic hot water temperature sensor is used for this application. The boiler is for closed loop applications only; open loop must not be directly heated by the boiler.
2. The sensor may be installed in the domestic hot water constant recirculation supply piping, or the domestic hot water storage tank.

3. See the **Operation** section for programming DHW priority. Refer to the **Hydronic PURE Control™ User Manual** for complete instructions.
4. When extending the wire lead, use 18 to 22awg twisted 2 conductor stranded copper with insulated jacket. Ensure connections are tight with no shorts. Soldered and heat shrink tubing connections are recommended. Never use wire nuts to join lead to extension.
5. For complete instructions, refer to the **Technical Data** sheet for the domestic hot water sensor prior to installation.

► MOTORIZED ISOLATION VALVE CONTROL

1. A contact is provided in the boiler control panel to operate a two-position motorized isolation valve. Contacts are rated for up to 7.4A at 120V. The valve type may be either power-open / power-close, power-open / spring-close, or spring-open / power-close. Depending on valve actuator type, a control relay may be required (not provided). Do not power the actuator using the boiler control power supplies.
2. Select a valve actuator with a cycle time from close to open, and open to close, of 45 seconds or less. Do not use slower valve actuators as they may result in system issues such as manual reset lockouts or poor temperature control response.
3. A motorized isolation valve is used in variable primary piping arrangements, in accordance with ASHRAE 90.1-2013, to prevent flow from traveling through idle boilers.
4. The lead boiler motorized isolation valve must be field programmed to remain open when all boilers are idle to provide a path of flow in the hydronic system. See the **Operation** section for programming motorized isolation valve control. Refer to the **Hydronic PURE Control™ User Manual** for complete instructions.

► AUXILIARY SAFETY INTERLOCK FOR EXTERNAL DEVICE

1. When the boiler receives a call for heat, the startup sequence checks the safety device limit string to the J5.1 terminal which includes the interlock contact.
2. Where used, the external device must close the interlock contact within 60 seconds of a call for heat or the boiler will enter an safety shutdown alarm state. An actuator with maximum 45 second speed or shorter is recommended. Ensure appropriate actuator selection to satisfy this timing requirement.

3. A jumper is factory installed in the interlock circuit. For applications requiring a safety interlock, this jumper may be removed with terminals wired into the dry contacts of an external device.
4. The interlock contacts provide a 24 VAC signal. **Do not apply an external power source to the interlock contacts; wire only to dry contacts.**
5. Typical uses for the safety interlock include but are not limited to: motorized isolation valve end switches, proof of exhaust draft assist fan operation, motorized air intake louvers.
6. Multiple safety interlocks may be used, wired in series.

► SYSTEM PUMP CONTROL

1. The boiler controller provides start/stop for one system (secondary) pump. Do not power the pump directly through the boiler panel.
2. The pump start/stop contacts has a maximum rating of 7.4 Amps at 120 VAC.

► DEDICATED BOILER PUMP CONTROL

1. Some installations may utilize primary-secondary piping arrangements instead of variable primary piping arrangements. In these instances, the boiler (primary) loop is decoupled from the system (secondary) loop, and a dedicated boiler pump will be required to provide flow through the boiler.
2. The boiler controller provides a dedicated boiler pump start/stop signal only; the pump cannot be powered through the boiler panel. An external motor starter or variable speed drive (not provided) is required to control the circulator pump.
3. The pump contact has a maximum rating of 7.4 Amps at 120 VAC.
4. Can be modulated by the boiler controller using the 4-20mA output provided. A signal converter (not provided) will be required for pump controls requiring a 0-10VDC signal.

▶ ALTERNATE COMMUNICATION PROTOCOL GATEWAY

Reference the **Protonode Start-Up Guide** for for BACnet protocol.

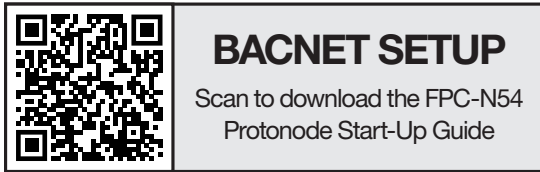

Communication between the boilers and the Protonode requires shielded three-wire twisted pair Belden 3106A or equivalent. To access the full points list of each boiler, the Modbus side of the Protonode wiring must be daisy-chained to all boilers. Shield must be grounded at one end only and tied directly to Earth ground. The Protonode may be powered by the 24VDC power supply in the boiler (V1+, V1-) or the power may be supplied by the Building Automation System. The Protonode requires field configuration through the Web GUI after installation.

▶ REMOTE BOILER ENABLE/DISABLE

1. A contact may be utilized to enable and disable each boiler individually. Remove the jumper and wire to remote control panel. The remote boiler enable/disable provides a 24 VDC signal. **Do not apply an external power source to the remote boiler enable/disable contacts; wire only to dry contacts.**
2. Closing the contact enables the boiler to start. When the contact is open, the boiler will remain in a disabled state.

▶ REMOTE ANALOG SETPOINT

1. An external hydronic loop setpoint may be sent using an analog 4-20 mA signal.
2. When using integrated lead/lag functionality, the setpoint signal may be sent to one boiler only.

▶ GENERAL ALARM CONTACT

A dry contact is provided for annunciation of a general alarm condition. It is rated for maximum 0.6 Amps at 24 VAC only.

▶ BOILER STATUS

1. For a boiler status contact closure indicating when the main gas valve is enabled, wire the coil side of a 24VAC relay (not provided) to the J5.2 contact located on the SOLA and TB2-XF1- terminal block.
2. Wire the remote system monitoring boiler status to the normally open contacts on the 24VAC relay.

▶ AUXILIARY(2ND) LOW WATER CUT OFF

1. This hydronic boiler includes one factory installed low water cut off (LWCO) device in compliance with CSD-1. Some authorities having jurisdiction (AHJ) may require the use of a 2nd (auxiliary) LWCO.
2. Where required, a probe type LWCO (P/N 4-30-000330) may be installed in the outlet piping of the boiler. The probe must not be isolated from the boiler by any valve.
3. Remove the jumper, and wire the external LWCO to the associated terminals. Install the LWCO relay.
4. Alternate LWCO devices may be used. They are wired to the same terminal blocks.

▶ FIELD DRAFT CONTROL SYSTEM

1. For connection to a field supplied mechanical draft control system which requires an enable signal from the boiler, install a relay (not provided) to the Boiler Flow Control (Primary Pump) enable contact. This is a dry contact with maximum rating of 120VAC 7.4A, the relay will be energized upon a heat demand when wired to the appropriate power source.
2. When using this contact for multiple devices such as a primary pump or motorized isolation valve, use a separate relay for each device.
3. The Demand Source setting for this contact must be set to "Local Burner".

4. This boiler includes a manifold pressure air switch safety which acts to safely shutdown the boiler in the event of a blocked exhaust, therefore an interlock to a mechanical draft control system is not required. Where an interlock is required by the AHJ, wire in series to the J5.1 "ILK" circuit. This is a 24VAC circuit, therefore ensure the draft control system provides a dry contact suitable for 24VAC. The draft system must close the interlock contact within 30 seconds of being enabled.

► **EMERGENCY STOP (E-STOP)**

1. A terminal is provided to perform an emergency shutdown of the boiler. Remove the jumper and wire to an emergency shutdown switch or remote control panel. Field wiring must be appropriate for the FLA listed on the boiler data plate located at the rear of the boiler.
2. Opening the contact will shut down the boiler.
3. The E-Stop terminal provides 120 VAC. **Do not apply an external power source to the E-Stop contacts; wire only to dry contacts.**

**WARNING**

All information in this manual is for reference and guidance purposes, and does not substitute for required professional training, conduct, and strict adherence to applicable jurisdictional/professional codes and regulations.

PAGE INTENTIONALLY LEFT BLANK

INTRODUCTION

1

INSTALLATION

2

OPERATION

3

MAINTENANCE

4

SERVICE DOCUMENTS

5

WARNING

All information in this manual is for reference and guidance purposes, and does not substitute for required professional training, conduct, and strict adherence to applicable jurisdictional/professional codes and regulations. Failure to follow instructions may result in a fire or explosion, causing property damage, personal injury, or loss of life.

This boiler is equipped with an ignition device, which automatically lights the burner. Do not try to light the burner by hand.

Do not store or use gasoline or other flammable vapors and liquids in the vicinity of this or any other appliances.

*Use only your hand to turn the valve handle. Never use tools. If the knob will not turn by hand, don't try to repair it. Call a qualified service technician. **FORCE OR ATTEMPTED REPAIR MAY RESULT IN A FIRE OR EXPLOSION.***

WHAT TO DO IF YOU SMELL GAS • Do not try to light any appliance. • Do not touch any electrical switch; do not use any phone in your building. • Immediately call your gas supplier from a neighbor's phone. Follow the gas supplier's instructions. • If you cannot reach your gas supplier, call the fire department.

A qualified installer, service agency or the gas supplier, must perform installation and service.

Do not use this boiler if any part has been under water. Immediately call a qualified service technician to inspect the boiler and to replace any impacted part of the control system.

Perform Pre-Start-Up Inspection

Prior to start-up, perform the following:

1. If you smell gas:
 - Do not try to light any appliance.
 - Do not touch any electrical switch; do not use any phone in your building.
 - Immediately call your gas supplier from a neighbor's phone.
2. Ensure the boiler is located with the proper clearances as shown in the **Clearances and Serviceability** section of this manual.
3. Ensure that relief valves have been properly piped to floor drains.
4. Ensure flue gas from the boiler is properly vented.
5. Ensure the water system has been flushed and is free of debris.
6. Ensure combustion air openings are not obstructed in any way and have adequate capacity.
7. Ensure there are no flammable liquids, materials or hazardous fumes present in the environment.
8. Ensure nothing was damaged or knocked loose during installation and/or shipment.
9. Inspect the main gas train and trim assembly to be sure they were not damaged during shipment and/or installation.

Fill and Purge the System

Completely fill and purge the heating system as follows:

1. Close combination shutoff/purge valve in supply, all drain cocks, the shutoff valve for the pressure reducing (fill) valve, and all manual air vents.
2. Open a system valve, or fill through a drain connection.
3. Water will now begin to fill the system. Open the safety relief valve. Continue filling until a constant stream of water (no bubbling) is discharged from the safety relief valve.
4. At this point, the system has been initially filled. However, air pockets may still remain at high points in the system and in heating loops above the level of the safety relief valve. It is quite possible, depending on the particular system that all piping above the safety relief valve still contains air. If manual vents are installed on the system high points, these should be opened to vent these locations. When only water is discharged from all vents, the initial purging is complete.
5. With the gas shutoff valve closed, turn on power to the boiler and operate the circulator. Circulate the system water for approximately 30 minutes to move all air to the automatic air separation point.

6. Check temperature/pressure indicator reading, which should equal the pressure-reducing (fill) valve set pressure. No more water should be entering the system. Close the shutoff valve on the cold-water fill line.
7. Visually inspect all pipe joints and equipment connections for leaks. If necessary, drain system, repair leaks and refill/purge the system. If no pressure drop is detected for a period of two hours under pressure, the system may be considered watertight.
8. When purging is completed, make sure the following are open— combination shut-off/purge valve, shutoff valve to pressure reducing (fill valve), shutoff valve in cold water fill line, and shutoff valve in return line.
9. Make sure the following are closed - all drain cocks, the vent on the combination shutoff-purge valve, & all manual vents. Reset zone valves to normal mode of operation and turn off power to boiler.
10. Open fuel shutoff valve, allowing fuel to flow to boiler.

Commission The Boiler

Adhere to the following when commissioning the boiler:

1. Verify with authorized personnel that the gas lines have been purged and leak tested. Do not proceed without verification.
 2. Familiarize all personnel on all aspects of boiler use, safety, and contents of this manual. This includes, but is not limited to, the use of the controls, lighting, and shutdown procedures.
 3. Review the unit-specific burner and control schematics, and follow appropriate instructions.
- **NOTE:** *Warranty coverage is valid only if the boiler is commissioned ("started up") by a factory authorized service technician with a valid Certificate of Authorization. The commissioning agency must successfully complete and return the Installation and Operation Checklist report ("Start-up Report") to Fulton within twelve (12) weeks of start-up. Combustion and maintenance records detailing compliance with the Installation, Operation and Maintenance manual must be produced for warranty consideration.*

■ System Design and Boiler Operation

This boiler must be installed in an appropriately designed system per **Installation** section of this manual.

1. The boiler shall be operated/controlled to ensure the boiler does not cycle more than 12,000 times per year and the temperature differential across the boiler does not exceed 50°F (27.8°C).
2. Site specific conditions including combustion air temperature, elevation, fuel temperature, calorific value of the fuel, combustion air system design, exhaust system design, voltage fluctuations and other factors will impact boiler performance.
3. Performance factors affected may include but are not limited to input/output ratings, efficiency, modulation rates and emissions.

WARNING

Do not attempt to start the boiler for any testing before filling and purging the boiler. A dry fire will seriously damage the boiler and may result in property damage or personnel injury and is not covered by warranty.

Before commissioning the boiler, verify with authorized personnel that the gas lines have been purged.

Never attempt to operate a boiler that has failed to pass all the safety checks.

CAUTION

Do not use this equipment if any part has been under water or subjected to heavy rains/water. Immediately call a qualified service technician to inspect the equipment and to replace any part of the control system and/or gas control(s) which have been under water.

The thermal shock warranty does not cover damage due to cyclic fatigue.

Never leave an opened manual air vent unattended. In the event an opened vent is left unattended, water damage could occur.

For systems using up to 50% glycol, a minimum 30 psi fill pressure is required at the boiler outlet.

Never operate a natural gas configured boiler on propane, even for temporary heat. Boilers factory test fired on natural gas must be converted by an authorized service technician before operating on propane.

 WARNING

All information in this manual is for reference and guidance purposes, and does not substitute for required professional training, conduct, and strict adherence to applicable jurisdictional/professional codes and regulations.

Tampering with safety devices or unauthorized bypassing of the boiler control system will void the pressure vessel warranty.

 CAUTION

Never operate a natural gas configured boiler on propane, even for temporary heat. Boilers factory test fired on natural gas must be converted by an authorized service technician before operating on propane.

Adjusting and Verifying Combustion

This boiler features Fulton's Flame-by-Wire™ electronic air-fuel ratio combustion control with integrated O2 Compensation™ technology. These systems simplify start-up and maintenance, minimize energy use, and autonomously tune the burner air-fuel ratio, automatically optimizing for seasonality.

Correct initial air-fuel adjustment is essential for the efficient and reliable operation of any boiler. After installation and before placing the boiler into service, a qualified technician must perform a combustion analysis and adjustment as necessary, also known as combustion commissioning. Periodic analysis, adjustment, and verification of the combustion system per the schedule in the **Maintenance** section will ensure many years of safe and reliable service. The qualified technician holding a valid Certificate of Authorization on the Endura XE should adhere to the following instructions.

■ Preparations Before Setting Combustion

1. Prepare a printed or digital copy of the appropriate form. Use the **Installation & Operation "Start-Up" Report (I&O)** when commissioning new equipment, and the **Annual Maintenance Checklist (MX)** for maintenance.
2. Prepare the required tools, refer to the Tool List in the Maintenance section for the complete list. At a minimum this will include a Slack Tube® or equivalent manometer, a combustion analyzer, a digital multimeter, a combustible gas detector, and necessary hand tools.
3. Wear proper Personal Protective Equipment (PPE) in accordance with site requirements.
4. Verify the boiler installation including fuel, power, venting, water pressure and flow are installed and operating in accordance with this manual. Ensure pumps and any motorized isolation valves are functional.
5. To gain access to necessary hardware and test port locations, remove the top and front cover panels of the boiler cabinet.
6. Verify the combustion analyzer is within calibration, inserted into the correct location shown in **Figure 23**, and set to the proper fuel type. Insert the combustion analyzer a maximum of 2" (50 mm) into the test port. If inserted too far you may witness unstable O2% readings on the analyzer at lower modulation rates.
7. Record the static (boiler idle) incoming gas pressure at the test port location shown in **Figure 8**. Incoming gas pressure is also referred to as supply, site, or inlet gas pressure.
8. Remove the cap on the factory gas train regulator.
9. Using the PURE Control touchscreen display located on the front cover panel, navigate to Configuration and verify the software version is up to date. If a newer version of the software is available, update before continuing. Refer to the **PURE Control™ User Manual** for instruction.

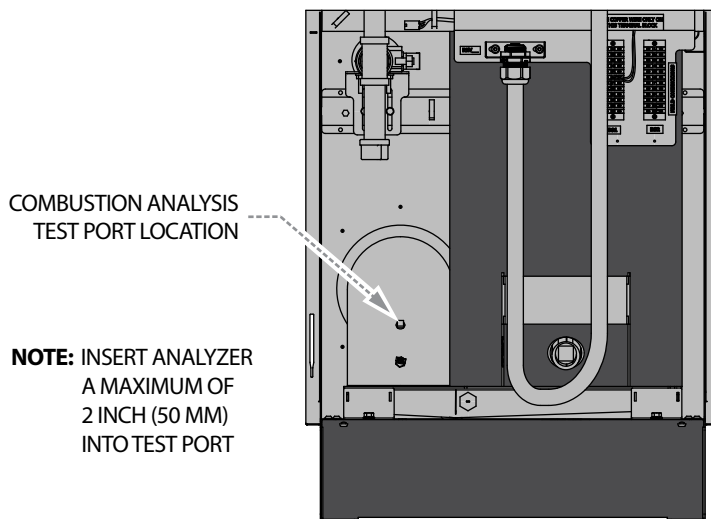

FIGURE 23 - COMBUSTION ANALYSIS TEST PORT LOCATION

10. Navigate to Tech Tools and then to the Commissioning screen. A password is required which is provided to authorized technicians who have completed service training.
11. Configure the Venting Material and Site Elevation parameters per site criteria.

■ Lighting the Burner and Stepping to P10

1. From the Commissioning screen, start the boiler and wait for pre-purge and ignition to complete.
2. Once main flame is established verify the Flue Gas Exhaust O₂% at P0 matches the value in **Table 8**. To tune O₂% adjust the degrees of Gas Position as necessary. At P0 a small change in Gas Position can have a large effect on P0 O₂%.
3. Tap either P3 or P4 Run, and confirm the selection.
4. Adjustments are not yet required upon reaching P3 or P4 unless necessary to maintain a stable flame or satisfy the manifold Air Switch. Begin stepping the combustion system towards P10 (100%, high fire). Each step should be no greater than one point at a time.
5. To maintain a stable flame while stepping up towards P10, adjustments may be made to MV Downstream fuel pressure using a screwdriver on the factory gas train regulator. MV Downstream is measured downstream of the second in-series main gas valve and upstream of the reduced port butterfly control valve, refer to **Figure 8**.
6. Measure Intake Manifold at each step and if necessary, adjust Air Position or Blower Position in accordance with Table 8 to increase the negative pressure to ensure the Air Switch remains satisfied before transitioning to the next point. Intake Manifold is measured on the air valve test port tee located on the inlet (suction) side of the combustion blower, refer to **Figure 24**.

WARNING

All information in this manual is for reference and guidance purposes, and does not substitute for required professional training, conduct, and strict adherence to applicable jurisdictional/professional codes and regulations.

Tampering with safety devices or unauthorized bypassing of the boiler control system will void the pressure vessel warranty.

WARNING

All information in this manual is for reference and guidance purposes, and does not substitute for required professional training, conduct, and strict adherence to applicable jurisdictional/professional codes and regulations.

Non-Fulton product information is for reference purposes only. No Fulton document should substitute for full review of documentation available from the component manufacturer.

Failure to set Intake Manifold Pressure in accordance with factory parameters may result in property damage, personal injury, or loss of life.

CAUTION

MV Downstream pressure must be set and verified at P10 prior to tuning combustion parameters at P10 and other points. Failure to set MV Downstream to factory parameters at P10 may result in improper or unpredictable operation of the O2 Compensation system, burner derate, or uneven modulation loading.

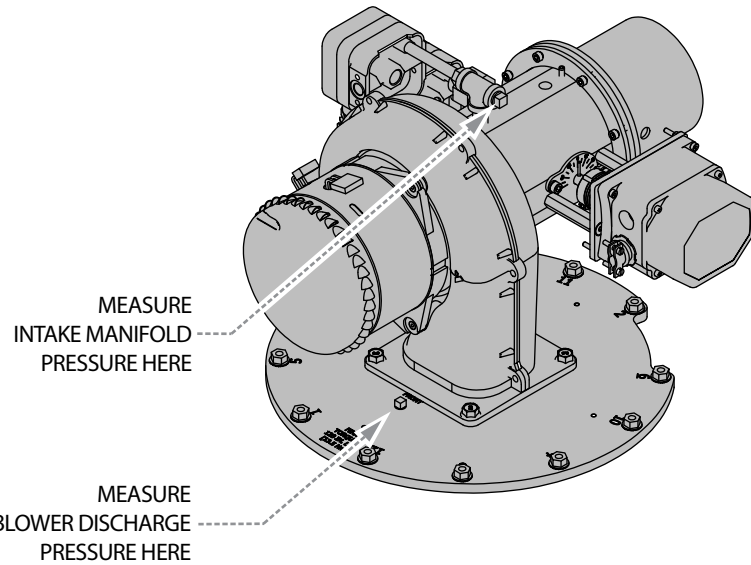

FIGURE 24 - INTAKE MANIFOLD AND BLOWER DISCHARGE PRESSURE MEASUREMENT LOCATIONS

■ Setting the Combustion Curve

The Test Fire Report is a factory quality and safety check and may not be reflective of appropriate settings for reliable operation in the field. After completing the previous steps above, refer to the combustion parameters in Table 8 and carefully adhere to the following:

1. Upon reaching P10, adjust Blower Position as necessary to ensure “Blower Discharge” pressure is set in accordance with **Table 8**.
2. Adjust Air Position to set Intake Manifold pressure in accordance with **Table 8**.
3. It is critical to safe and reliable operation to set MV Downstream gas pressure at P10. Using a screwdriver on the factory gas train regulator, adjust MV Downstream to within the range listed in **Table 8**.
4. After setting and verifying MV Downstream, adjust P10 Gas Position as necessary to set the O2% in accordance **Table 8**.
5. Repeat steps 1 through 4 to ensure all parameters are set in accordance with **Table 8**.

► **NOTE:** For P10 adjustment set Fan Discharge pressure first, then set Intake Manifold pressure, then set MV Downstream pressure, and finally adjust Gas Position for O2% in this order. MV Downstream must be set only after Fan Discharge and Manifold pressure are within the P10 ranges listed in Table 8.

6. Verify the dynamic (high fire) incoming gas pressure meets both the range on the data plate at the rear of the boiler and does not drop more than 15% from the static incoming gas pressure measurement previously recorded. If excessive incoming gas pressure drop is observed this is typically due to undersized field gas piping and/or an undersized field line pressure regulator. For reliable operation, the installing contractor must resolve gas pressure issues. Recommission the boiler after gas pressure issues are successfully resolved.
7. Re-install the cap on the factory gas train regulator. Adjustments to MV Downstream are only made at P10.
8. Carefully check for gas leaks along the field gas piping, factory gas train, pre-mix system (blower discharge region) and exhaust collection and disposal systems. A GAS-Mate® 0119 combustible gas detector or equivalent is recommended. The detection level must not exceed Level 1 (500 ppm), measurements below Level 1 are considered a safe and acceptable condition.
9. After completing P10, step down the curve adjusting the Air Position, Gas Position and Blower Position at each point as necessary to achieve the necessary Intake Manifold pressures and O₂% values in accordance with factory provided combustion parameters. Blower Position must have a minimum separation of 100 RPM between points. Do not adjust MV Downstream at P0-P9.
10. Upon reaching P1, verify the Blower Discharge pressure is greater than the value listed in Table 8. Do not set Gas Position to a lower degree than the value found on the factory Test Fire Report, however it is acceptable to increase the Gas Position. Should P1 O₂% need to be increased, do not lower the Gas Position, instead increase Air Position and/or Blower Position. To verify repeatability, it is good practice to cycle the burner and measure and adjust P1 two additional times.
11. After completing P1, check and adjust O₂% at Ignition (P0).
12. Ensure all parameters at all points are documented on the I&O or MX form.
13. Shut off the boiler to disable the burner.

■ Verifying Safeties and Ignition Reliability

1. Verify the Blocked Intake Switch and manifold Air Switch are both set to 1.0 "W.C.
2. Verify the Low Gas Pressure Switch is set to 3.0 "W.C.
3. Verify the High Gas Pressure Switch is set to 6.0 "W.C.
4. Cycle the boiler a minimum of 10 consecutive times to verify reliable ignition.



WARNING

All information in this manual is for reference and guidance purposes, and does not substitute for required professional training, conduct, and strict adherence to applicable jurisdictional/professional codes and regulations.

Non-Fulton product information is for reference purposes only. No Fulton document should substitute for full review of documentation available from the component manufacturer.



CAUTION

Tampering with safety devices or unauthorized bypassing of the boiler control system will void the pressure vessel warranty.

 WARNING

All information in this manual is for reference and guidance purposes, and does not substitute for required professional training, conduct, and strict adherence to applicable jurisdictional/professional codes and regulations.

Non-Fulton product information is for reference purposes only. No Fulton document should substitute for full review of documentation available from the component manufacturer.

 CAUTION

Never operate a natural gas configured boiler on propane, even for temporary heat. Boilers factory test fired on natural gas must be converted by an authorized service technician before operating on propane.

■ Upon Successful Completion

1. When leaving the Commissioning screen, confirm to save combustion settings.
2. Alternatively, navigate to Configuration, File Manager, SD Card Operations, tap Save Settings to SD Card and confirm the selection.
3. Place the boiler into automatic operation and adjust local set point to verify the boiler is responding accordingly with quiet, repeatable, and reliable combustion.
4. Replace all test port plugs using the appropriate thread sealant.
5. Reinstall the cabinet front door and top cover.
6. Complete all remaining installation details, safety checks and measurements on the appropriate I&O or MX form. Do not skip this critically important step or leave fields blank. Maintaining accurate and complete records facilitates future service and troubleshooting.
7. Leave a copy of the I&O or MX form with the boiler or the appropriate site contact. Retain a copy for your records in a safe location.
8. For new equipment start-up, warranty coverage is valid only if the I&O form is successfully completed and returned to the Fulton factory service coordinator within twelve weeks of start-up.

► *NOTE: Accurate and complete combustion and maintenance records detailing compliance with the Installation, Operation and Maintenance manual must be produced for warranty consideration.*

Combustion Parameters

For safe, reliable, and efficient performance, operate the burner in accordance with the following combustion parameters:

- NOTE: Factory Test Fire is a quality and safety check performed under controlled conditions. The parameters documented in the factory Test Fire Report are not intended to serve as commissioning settings. While Test Fire Report values may be used as a general reference, the commissioning technician must account for actual site specific installation and application criteria including venting configuration, wind effects on terminations, natural draft "stack effect", fuel gas delivery, emissions standards, and elevation which will ultimately determine the appropriate settings and optimal burner turndown for safe and reliable operation.

TABLE 8 - NATURAL GAS COMBUSTION PARAMETERS

EXE-399		P0	P1 ¹	P2 to P4	P5	P6	P7	P8	P9	P10 ²
O2	%	5.2 to 5.6	6.0 to 7.0	6.0 to 7.4	6.0 to 7.4	4.5 to 7.0	4.5 to 6.8	4.5 to 6.7	4.5 to 6.6	4.5 to 6.5
Manifold	"WC	-1.45 to -1.55	-1.35 to -1.25	-1.35 to -1.25	-1.35 to -1.25	-1.35 to -1.25	-1.35 to -1.25	-1.35 to -1.25	-1.35 to -1.25	-1.35 to -1.25
MV Downstream	"WC									2.95 to 3.05
Fan Discharge	"WC		>0.13							4.0 to 4.4

EXE-500		P0	P1 ¹	P2 to P4	P5	P6	P7	P8	P9	P10 ²
O2	%	5.2 to 5.6	6.0 to 7.0	6.0 to 7.4	6.0 to 7.0	4.5 to 6.7	4.5 to 6.6	4.5 to 6.5	4.5 to 6.5	4.5 to 6.3
Manifold	"WC	-1.45 to -1.55	-1.35 to -1.25	-1.35 to -1.25	-1.35 to -1.25	-1.35 to -1.25	-1.35 to -1.25	-1.35 to -1.25	-1.35 to -1.25	-1.35 to -1.25
MV Downstream	"WC									2.55 to 2.65
Fan Discharge	"WC		>0.13							6.3 to 6.9

EXE-650		P0	P1 ¹	P2 to P4	P5	P6	P7	P8	P9	P10 ²
O2	%	5.4 to 5.8	6.0 to 7.0	6.0 to 7.4	4.5 to 6.7	4.5 to 6.5	4.5 to 6.5	4.5 to 6.3	4.5 to 6.1	4.5 to 6.0
Manifold	"WC	-1.75 to -1.85	-1.20 to -1.30	-1.20 to -1.30	-1.20 to -1.30	-1.20 to -1.30	-1.20 to -1.30	-1.20 to -1.30	-1.20 to -1.30	-1.20 to -1.30
MV Downstream	"WC									2.05 to 2.15
Fan Discharge	"WC		>0.13							8.6 to 9.5

EXE-750		P0	P1 ¹	P2 to P4	P5	P6	P7	P8	P9	P10 ²
O2	%	5.4 to 5.8	6.0 to 7.0	6.0 to 7.4	4.5 to 6.5	4.5 to 6.5	4.5 to 6.3	4.5 to 6.1	4.5 to 6.0	4.5 to 5.8
Manifold	"WC	-1.75 to -1.85	-1.20 to -1.30	-1.20 to -1.30	-1.20 to -1.30	-1.20 to -1.30	-1.20 to -1.30	-1.20 to -1.30	-1.20 to -1.30	-1.20 to -1.30
MV Downstream	"WC									1.50 to 1.60
Fan Discharge	"WC		>0.13							11.7 to 13.3

NOTES:

- Never decrease gas position at P1. Ensure flame signal at P1 is >40% (10V), higher is better.
- MV Downstream must be set at P10 prior to setting combustion at all other points. Do not adjust MV Downstream at any other point.
- Measurements should be recorded using a Slack Tube[®] manometer or equivalent. The use of a digital manometer is not recommended.
- Minimum and maximum burner rates may vary based on site specific criteria and adherence to boiler installation and operation requirements.
- A calibrated gas flow meter (not provided) may be used to measure fuel input rates.
- These parameters are appropriate for woven metal mesh burners only.

WARNING

All information in this manual is for reference and guidance purposes, and does not substitute for required professional training, conduct, and strict adherence to applicable jurisdictional/professional codes and regulations.

Non-Fulton product information is for reference purposes only. No Fulton document may substitute for full review of documentation available from the component manufacturer.

CAUTION

A temperature exceeding 104°F** (40 C) in the boiler room may cause premature failure of electrical components. Provisions should be made to maintain an ambient temperature of 104°F** (40 C) or less.

****Pumps, PLC or ModSync panels may require lower ambient temperatures or additional cooling.**

This hydronic heating boiler is not suitable for use as a domestic water heater. Do not heat potable water, such as used for showers, sinks, dishwashers, or washdown process directly through the boiler.

Using the PURE Control® Interface

Reference the **PURE Control™ User Manual** for detailed instructions on the controls system. The boiler control system features an integrated color touchscreen display through which many commissioning and operation tasks are performed, including temperature control and lead-lag configuration. The graphical interface is navigated by touch using your finger or a stylus. The screenshots and information in this section will guide you through the menu screens.

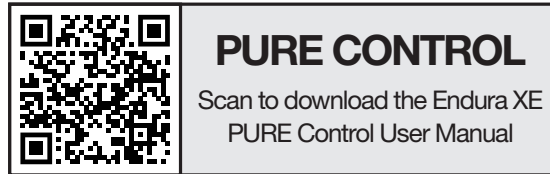

■ Navigation

The Main Menu (“Dashboard”) groups screens where functions are accessed into the following categories: Boiler, Lead/Lag, PID, Temperature, Circulation, Alarm History, Configuration and Tech Tools. To enter a category, tap the tile. The Boiler and Alarm History tiles are live, and will display operating information when applicable.

While on a screen, return to the Main Menu at any time by clicking the menu button located at the top left. While on the Main Menu, return to the screen in use by tapping the X button located at the top left.

Screens are context sensitive for ease of use, meaning selections made will dynamically change the user interface and display relevant functions.

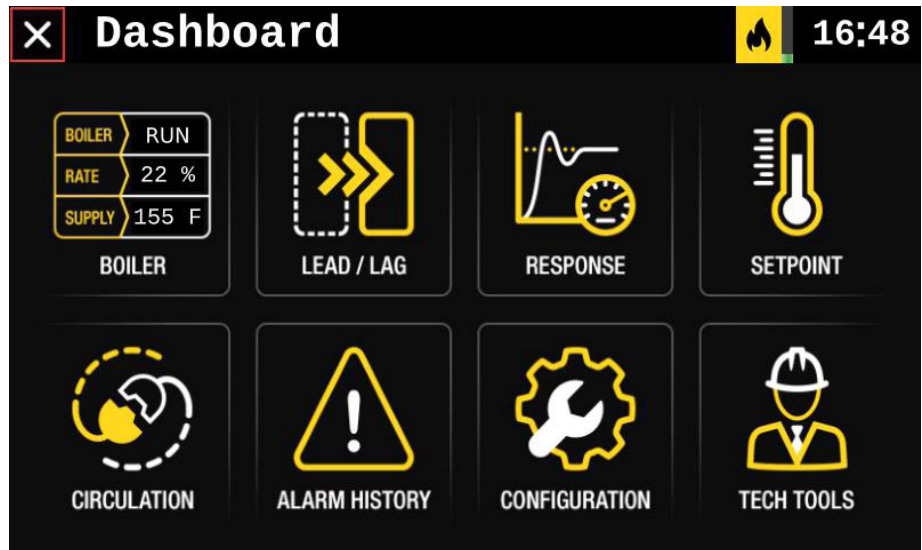

PURE Control® Menu Screens

■ Boiler

General individual boiler and ancillary functionality is accessed through this category.

▶ STATUS

Summarizes detailed operating information and sensor status for the boiler.

▶ DEMAND

Devices will either have a green circle to the left indicating closed circuit or a red circle indicating the device is open. The device indicated as the “open limit” is the first device in the safety circuit open and should be the first device addressed during troubleshooting.

Call for heat requires at least one condition to be green. If all are gray, the boiler will remain in an idle (standby) condition.

▶ CONTROL

When in Automatic Control, the temperature controller will modulate the burner to a firing rate necessary to achieve the setpoint. To enter Manual Control, tap the “Automatic Control” button, and it will change to “Manual Control.” Enter a “Manual Firing Rate” in the box, and press OK to confirm. When finished with maintenance or testing, return to this screen and place the boiler back into Automatic Control.

▶ HISTORY

Various data points of operational history including run hours, power-on hours, cycles, and estimated (calculated) efficiency are summarized on this screen.

■ Alarm History

This screen provides a chronological list of alarms. Pressing the “View Alarm Info” button will expand a selected alarm for additional information and troubleshooting tips.

■ Circulation

Three pump contacts are provided for a primary (dedicated boiler) pump, a secondary (system) pump, and a domestic hot water (dhw) pump. Pump contacts may also be used for a motorized isolation valve in lieu of a pump, for example in a variable primary piping arrangement.

Each contact may be placed in manual control or automatic. When using manual on the primary pump contact, ensure all boilers are not placed in manual close while the system pumps are in operation. In automatic control, a Close Delay Timer can be set to keep the contact closed for the prescribed time when a boiler no longer



WARNING

All information in this manual is for reference and guidance purposes, and does not substitute for required professional training, conduct, and strict adherence to applicable jurisdictional/professional codes and regulations.

Non-Fulton product information is for reference purposes only. No Fulton document should substitute for full review of documentation available from the component manufacturer.

WARNING

All information in this manual is for reference and guidance purposes, and does not substitute for required professional training, conduct, and strict adherence to applicable jurisdictional/professional codes and regulations.

Non-Fulton product information is for reference purposes only. No Fulton document should substitute for full review of documentation available from the component manufacturer.

has a call for heat. The Delta T Close Delay feature will hold the contact closed until residual heat is removed from the heat exchanger and the Delta T drops to the selected value. When enabled, both conditions must be satisfied. For variable primary flow applications utilizing motorized isolation valves, select to enable one contact to always remain closed when lead/lag is used.

The primary (dedicated boiler) pump contact closes upon local burner demand, and opens upon the prescribed delay settings.

The secondary (system) pump contact is closed at all times while the boiler plant is enabled and allowed to run, even while no burners are operating. This contact opens upon the prescribed delay settings.

The DHW pump contact closes upon DHW heat demand, and opens upon the prescribed delay settings.

■ Lead/Lag

▶ CONFIGURATION

Integrated multiple boiler sequencing “Lead/Lag” is configured and monitored through this category. Ensure the boilers are on a private Ethernet/IP network shared with no other devices before continuing setup.

To function properly on the network, the **Local Ethernet/IP Address** of each boiler must be configured per the following:

Boiler 1 – 192.168.1.100	Boiler 6 – 192.168.1.105
Boiler 2 – 192.168.1.101	Boiler 7 – 192.168.1.106
Boiler 3 – 192.168.1.102	Boiler 8 – 192.168.1.107
Boiler 4 – 192.168.1.103	Boiler 9 – 192.168.1.108
Boiler 5 – 192.168.1.104	Boiler 10 – 192.168.1.109

Wire the boiler in accordance with the instructions detailed in the Installation section. Wiring for the Ethernet/IP network will change based on the number of boilers in the system. For systems with two boilers, a single Ethernet cable can be wired directly between the boilers. For systems with more than two boilers, each boiler will require an Ethernet home run back to the Ethernet switch (ships loose in trim kit when ordered).

Set the Number of Boilers field to the number of boilers to be controlled. These steps must be completed at each boiler. Ensure the **Universal Data**, is properly configured for data sources.

- *Lead/Lag priority* determines how the boilers are sequenced, either by cycles only, hours only, or an optimized algorithm.
- *Number of boilers* displays how many boilers the Lead/Lag system expects to have under control.
- *Lead start* is how far below setpoint before the lead boiler turns on.
- *Lead stop* is how far above setpoint before the lead boiler turns off.

► COMMUNICATION

View the status of lead/lag network communication.

► UNIVERSAL DATA

The Universal Data system allows the boilers to share vital data over the Ethernet/IP Boiler Network without having to wire individual sensors to each boiler, or write commands to each boiler. Configure the Universal Data sources at each boiler, for that specific boiler.

- Physically Wired – The control will look to its own I/O inputs for the information it needs and will then share that information with the Boiler Network.
- Boiler Network – The control will look to the local Ethernet/IP network for the information it needs. In order for this to work, one boiler will need to share that information with the network setup as either physically wired or BMS network.
- BMS Network – The control will look to the Building Management Network for the information that it needs and will share it with the rest of the boiler network.
- Please note that each signal/sensor can be independently configured, meaning one boiler could provide a setpoint to the boiler network, and another could provide the system header temperature, for instance.

■ PID

Proportional Integral Derivative (PID) control is used to modulate the burner or burners as a response to heat demand in the system. Proper setup of the PID specific to your application is necessary and will directly impact temperature response. In typical applications a full-passive response is desired, this will reduce boiler cycling, reduce maintenance, and prevent temperature overshoots.

The Local PID slider is used for local demands, when the boiler is operating in standalone mode.

The Lead/Lag PID is used when utilizing the integrated Lead/Lag functionality. Ensure the Lead/Lag PID is configured to the same setting on each boiler in the plant, failure to do so many result in unexpected temperature response when the Network Originator changes.

Local PID and firing rate modifiers are accessed in this category.

► PID OVERRIDES

Low Fire Hold will lock the burner at a low fire rate after ignition for a set period of time.

Two stages of freeze protection are provided. Stage 1 is only available if the boiler



WARNING

All information in this manual is for reference and guidance purposes, and does not substitute for required professional training, conduct, and strict adherence to applicable jurisdictional/professional codes and regulations.

Non-Fulton product information is for reference purposes only. No Fulton document should substitute for full review of documentation available from the component manufacturer.

 **WARNING**

All information in this manual is for reference and guidance purposes, and does not substitute for required professional training, conduct, and strict adherence to applicable jurisdictional/professional codes and regulations.

Non-Fulton product information is for reference purposes only. No Fulton document should substitute for full review of documentation available from the component manufacturer.

(primary) pump is enabled in a primary secondary piping system. When the boiler vessel water temperature falls below a configured temperature, the boiler (primary) pump will be enabled until the set temperature has been reached.

Stage 2 enables the burner if the boiler vessel water temperature falls below a configured temperature. The burner is held at low fire until the set temperature has been reached.

► *NOTE: If a high temperature condition occurs exceeding the high limit setting the boiler will require a manual reset.*

The Soft Limit acts to prevent nuisance manual reset high limit trips. If the boiler outlet temperature exceeds the soft limit, the burner will be driven to low fire until the outlet temperature is reduced to the value assigned in the Soft Limit Reset.

Cold Start allows the boiler to slowly reach temperature when receiving a demand at a cold water condition as configured. When enabled, this will take priority over the PID until the configured time or the configured boiler water temperature is reached.

► ANTI-CYCLE

This function is an override of burner demand, and not the PID while the burner is in operation. When enabled, the timer begins a count-down when the heat demand ends, and the burner will not be re-enabled until the anti-cycle timer expires.

■ Temperature

The boiler or multiple boiler system will maintain supply water temperature based on a setpoint temperature. This setpoint can come from a variety of sources, including by calculation from an outdoor air temperature sensor, a remote signal from the Building Management System (BMS), or from a static manually entered setpoint.

► SETPOINT

The Setpoint Source allows for the selection between the various setpoint sources available.

When in Outdoor Reset mode, the control will automatically calculate the hydronic loop setpoint based on the settings configured on the **Outdoor Reset** screen.

BMS Analog will monitor the 4-20mA contact for a remote setpoint signal. Enter the linearization settings to properly scale the signal to the desired temperature setpoints.

When in Modbus mode, the control will maintain setpoint based on the Modbus RTU write point. Protocol conversion gateways are available for alternate communication protocols including BACnet and LonWorks.

Local (Fixed) is used for static setpoints.

▶ OUTDOOR RESET

Separately entries are available for Occupied and Unoccupied modes.

The hydronic loop temperature setpoint will be calculated based on configured outdoor air and setpoint high and low temperature values. When the outdoor air temperature reaches a warm weather shutdown Outdoor Air Cutoff temperature, the boilers will be disabled until outdoor air temperature has decreased by the value assigned in the Cutoff Reset.

▶ SCHEDULING

The Scheduling system allows for the operator to configure when the normal (occupied) setpoint will be maintained. When outdoor reset is enabled, the normal setpoint curve will establish setpoint during these time frames with the setback (unoccupied) setpoint curve establishing setpoint for all other times.

■ Configuration

Functions are used during initial commissioning, troubleshooting and other tasks.

▶ SYSTEM CONFIGURATION

The System Configuration screen is used for saving (backup) and loading of program settings. The backup battery status is shown in the bottom right of the screen. Loss of power without an operational battery will result in lost program settings.

▶ SENSORS

An overview of boiler and auxiliary sensor status is available on this screen. Sensor offset values may be configured for calibration purposes.

▶ USER CONFIGURATION

An administrator password can be assigned to the control to prevent unauthorized access. The selected screens will require entry of the administrator password prior to access. The password may be up to 10 characters in length.



WARNING

All information in this manual is for reference and guidance purposes, and does not substitute for required professional training, conduct, and strict adherence to applicable jurisdictional/professional codes and regulations.

Non-Fulton product information is for reference purposes only. No Fulton document should substitute for full review of documentation available from the component manufacturer.

 **WARNING**

All information in this manual is for reference and guidance purposes, and does not substitute for required professional training, conduct, and strict adherence to applicable jurisdictional/professional codes and regulations.

Testing Safety Devices

■ Perform Test of Limit Controls

1. Ensure appropriate water flow is available per requirements listed in **Table 1**. Place the boiler into Manual firing rate control, and increase loop water temperature until a high limit lock out occurs.
2. Allow the boiler to cool, and acknowledge the alarm.

■ Perform Test of Low Gas Pressure Switch

► *NOTE: This applies only to CSD-1 boilers.*

1. With the boiler running, turn up the low gas pressure switch setting until a lock out occurs.
2. Acknowledge the alarm, return to the factory recommended setting and reset the switch.

■ Perform Test of High Gas Pressure Switch

► *NOTE: This applies only to CSD-1 boilers.*

1. With the boiler running, turn down the high gas pressure switch setting until a lock out occurs.
2. Acknowledge the alarm, return to the factory recommended setting and reset the switch.

■ Perform Test of Low Water Cut Off

1. With the boiler idle, turn the switch on the front of the boiler to the left position for approximately 3 seconds. Observe the light switching off on the Low Water Cut Off relay.
2. Turn the switch to the right position, an alarm will be recorded.
3. Return the switch to the center position and acknowledge the alarm.
4. To reset the Low Water Cut Off relay, briefly turn the switch to the left position. Perform reset quickly or the test sequence will repeat.

■ Perform Test of Manifold Air Switch

1. Increase the air switch setting to the maximum value and attempt to run the boiler. A lock out should occur during pre-purge.
2. Acknowledge the alarm, return to the factory recommended setting and reset the switch.

INTRODUCTION

1

INSTALLATION

2

OPERATION

3

MAINTENANCE

4

SERVICE DOCUMENTS

5

WARNING

Prior to any maintenance concerning electrical components of this equipment, ensure electrical supply to the equipment is disconnected. Label all wires prior to disconnection; wiring errors may cause improper and hazardous operation.

Follow all proper lockout/tagout procedures for service.

Before beginning any maintenance, ensure area is free of any combustible materials and other dangers.

*What to do if you smell gas:
Do not try to light the appliance.
Do not touch any electrical switch.
Do not use any phone in the building.
Leave building and contact gas supplier from neighbor's phone. If you cannot reach gas supplier, phone the fire department.*

Combustion control settings and fuel pressures must only be adjusted by a qualified technician.

CAUTION

All information in this manual is for reference and guidance purposes, and does not substitute for required professional training, conduct, and strict adherence to applicable jurisdictional/professional codes and regulations.

All maintenance procedures should be completed by trained personnel. Appropriate training and instructions are available through your local Fulton Representative.

In order to meet warranty conditions, ensure all appropriate maintenance activities are performed, and successfully documented.

General

This boiler has been designed to provide years of trouble free performance. To ensure continued safety and efficiency of the boiler, please follow the maintenance and inspection directions outlined in this section of the manual.

Daily, Weekly and Monthly Maintenance and Inspection are considered good practice for any boiler. It is also good practice for any boiler installation to perform a thorough review of the overall system on a regular basis, and after any maintenance procedures. Any potential issues should be noted and followed up on to ensure safety and reliability of all relevant equipment. System review items may include:

- Looking for discoloration of any painted equipment, boiler jacket panels, and/or insulation used in system piping.
- Carefully checking for gas leaks using a combustible gas detector during commissioning and regular inspections; a GASMate® 0119 or equivalent is recommended. This includes, but is not limited to: Gas delivery system, gas train fittings, pressure switches, gas valves, regulators, conduit connections to gas devices, and pre-mix delivery components.
- Looking for evidence of leaks including the air intake/exhaust systems, boilers, hydronic system piping, pumps, valves and other system components.
- Once boilers are running, making sure there are no flue gases around the boilers, or in the boiler room.

► *NOTE: Combustion analysis and adjustment schedule can vary based on boiler application and seasonal conditions. Biannual or quarterly adjustment may be optimal in some applications—for example, systems operating as both winter heat and summer reheat.*

Tool List

To complete routine preventative maintenance or repairs, certain tools and supplies will be required that are not provided with the boiler. The qualified service technician should be prepared with the following tools and supplies.

- Digital Multimeter (DMM)
- 16GB to 32GB USB Flash Drive (FAT32 format only) with the current PURE Control Software
- Maintenance Checklist Form and Pen/Pencil
- Slack Tube® Manometer or Equivalent
- GAS-Mate® Combustible Gas Leak Detector or Equivalent
- Calibrated Flue Gas Analyzer
- Calibrated Calipers
- Calibrated Torque Wrench
- Calibrated Torque Screwdriver
- 2.5MM Allen Hex Drive for Torque Screwdriver
- Pipe Wrenches
- Crescent Adjustable Wrench
- Blade (Flat-Head) and Phillips Screwdriver Set
- Socket Wrench
- Metric Socket Set
- Metric Allen/Hex Key Wrench or Socket Set
- Grade #00 Very Fine Steel Wool Pad
- Super O-Lube or Equivalent
- Permatex® Dielectric Grease or Equivalent
- Loctite LB8150 Silver Grade Anti-Seize or Equivalent
- Loctite C5-A Copper Anti-Seize or Equivalent
- Loctite 242 or Equivalent
- Appropriate Personal Protective Equipment (PPE)
- Lockout-Tagout (LOTO) Tags



WARNING

Never use open flame or other sources of ignition to check for gas leaks.

Ensure boiler is off and cooled, with proper lockout - tagout per local codes prior to service and maintenance.

Follow proper safety precautions when using a ladder.



CAUTION

All information in this manual is for reference and guidance purposes, and does not substitute for required professional training, conduct, and strict adherence to applicable jurisdictional/professional codes and regulations.

Use caution when using any cleaning solutions. Refer to local regulations for proper cleaning solution disposal.

Do not allow dust or dirt to accumulate around the boiler.

WARNING

Never use open flame or other sources of ignition to check for gas leaks.

Follow proper safety precautions when using a ladder.

Ensure boiler is off and cooled, with proper lockout - tagout per local codes prior to service and maintenance.

CAUTION

All information in this manual is for reference and guidance purposes, and does not substitute for required professional training, conduct, and strict adherence to applicable jurisdictional/professional codes and regulations.

All maintenance procedures should be completed by trained personnel. Appropriate training and instructions are available through your local Fulton Representative.

In order to meet warranty conditions, ensure all appropriate maintenance activities are performed.

Burner gaskets must not be reused. Gasket is designed for one-time use only.

Using nuts and washers not provided by Fulton can lead to flue gas leakage and cause damage to the studs.

Daily Inspection Schedule

Daily inspection must include the following:

1. Observe operating temperature and general conditions.
2. Make sure that the flow of combustion and ventilating air to the boiler is not obstructed.
3. Make sure the boiler area is free and clear of any combustible materials, including flammable vapors and liquids.

Weekly Inspection Schedule

Weekly inspection must include the following:

1. Observe the conditions of the main flame. Correct fuel/air adjustment is essential for the efficient and reliable operation of this boiler. Refer to Table 8 in the Operation section. If an adjustment to the combustion is necessary, use a calibrated flue gas analyzer and document changes in the maintenance records.

Monthly Inspection Schedule

Monthly inspection must include the following:

2. Test limit controls and switches using the **Testing Safety Devices** procedure in the Operation section of this manual.
3. Check flue gas temperature at outlet. If there is a temperature increase over previous readings, the probable cause is soot or water-scale build-up on the tubes. Consult your Fulton Representative immediately if there is a concern.

Replacing or Updating the Boiler Control

Update the software or firmware when directed by the factory. Lead/Lag integration requires the same firmware and software version on all units.

It is recommended to always update to the latest software when commissioning new boilers.

Annual Maintenance Schedule

Annual maintenance must be completed and properly documented by a factory authorized technician holding a valid Endura XE Certificate of Registration to maintain warranty coverage. Schedule your annual maintenance to be performed prior to the start of each heating season, which includes, but is not limited to, the following tasks:

1. Inspect the fuel train, burner and control panel to be sure components are free of debris and are properly attached to the boiler.
2. Examine the venting system (combustion air intake and special gas vent).
 - Check all joints and pipe connections for tightness.
 - Check piping for corrosion or deterioration.
 - Check that the piping is clear of debris.
 - Check that the condensate drain system is functioning.
3. Inspect the hydronic heating system water chemistry and functionality.
4. Carefully check for gas leaks using a combustible gas detector; a GASMate® 0119 or equivalent is recommended. This includes, but is not limited to: Gas delivery system, gas train fittings, pressure switches, gas valves, regulators, conduit connections to gas devices, and pre-mix delivery components.
5. Clean the low water cut-off probe(s).
6. Remove and inspect burner. Clean as necessary. See **Removing and Cleaning Burner** section of this manual.
7. Replace the flame rod with new and verify the gap to the burner is properly set. See **Removing and Cleaning Flame Rod** section of this manual.
8. Direct spark ignition replaced with new and gap properly set. See **Verification of Ignition Electrode Gap** section of this manual.
9. Perform test of boiler safety devices.
10. Update the PURE Control™ software to the current version (where applicable, as directed by the factory).
11. Address any open factory Service Bulletin(s), where applicable.
12. Test pressure relief valve by lifting the lever for 5 seconds and allowing the valve to snap shut. Refer to the manufacturer's instructions on the relief valve tag. Relief valves are considered wear items, and must be replaced if leaking.
13. Perform combustion analysis and adjust if necessary. Refer to **Adjusting and Verifying Combustion and Combustion Parameters** in the Operation section. A low O₂ level or harmonic can indicate a need for burner service.

WARNING

Never use open flame or other sources of ignition to check for gas leaks.

Ensure boiler is off and cooled, with proper lockout - tagout per local codes prior to service and maintenance.

Follow proper safety precautions when using a ladder.

Personnel performing burner assembly maintenance must wear appropriate respiratory protection. Failure to do so may result in the inhalation of refractory ceramic fibers.

CAUTION

All information in this manual is for reference and guidance purposes, and does not substitute for required professional training, conduct, and strict adherence to applicable jurisdictional/professional codes and regulations.

Use caution when using any cleaning solutions. Refer to local regulations for proper cleaning solution disposal.

Do not allow dust or dirt to accumulate around the boiler.

WARNING

Never use open flame or other sources of ignition to check for gas leaks.

Follow proper safety precautions when using a ladder.

Ensure boiler is off and cooled, with proper lockout - tagout per local codes prior to service and maintenance.

Personnel performing burner assembly maintenance must wear appropriate respiratory protection. Failure to do so may result in the inhalation of refractory ceramic fibers.

CAUTION

All information in this manual is for reference and guidance purposes, and does not substitute for required professional training, conduct, and strict adherence to applicable jurisdictional/professional codes and regulations.

All maintenance procedures should be completed by trained personnel. Appropriate training and instructions are available through your local Fulton Representative.

In order to meet warranty conditions, ensure all appropriate maintenance activities are performed.

Burner gaskets must not be reused. Gasket is designed for one-time use only.

Using nuts and washers not provided by Fulton can lead to flue gas leakage and cause damage to the studs.

Where removing the blower from the blower discharge transition, the o-ring must be replaced.

Removing and Cleaning Burner Assembly

Disassemble, inspect, and clean as follows:

1. Remove power and turn off gas supply. Allow the boiler to cool.

► *NOTE: The boiler cabinet is not a step; it must not be used to support a person's weight*

2. Disconnect wires from the ignition and flame rod assemblies.
3. Remove the ignition assembly.
4. Remove the flame rod.
5. Remove the hardware securing the burner plate to the combustion chamber.

► *NOTE: Due to unique hardware specifications, alternate hardware must not be substituted. If hardware is lost or damaged, contact your Fulton representative for replacement.*

6. Remove blower discharge transition.
7. Remove burner gasket.
8. Remove the burner from the combustion chamber.

► *NOTE: Do not use liquids or brushes when cleaning the burner.*

9. Use compressed air to clean the burner.
10. If any burner damage is detected, contact your Fulton Representative.

Reassemble in reverse order as follows:

11. Replace the burner gasket with new. Refer to **Parts Diagrams**.
12. Apply C5-A copper anti-seize to burner hardware threads and install nuts finger tight to the premix plate. Use only genuine hardware provided by Fulton. Do not substitute hardware.
13. Torque burner flange nuts in three stages per the pattern etched onto the premix plate. First to 36 in-lbs (4.07 N-m), then to 72 in-lbs (8.13 N-m), and finally to 120 in-lbs (13.6 N-m).
14. Reinstall flame rod or new flame rod. See **Removing & Cleaning Flame Rod** for instructions.
15. Reinstall ignitor or new ignitor. See **Servicing the Direct Spark Ignition Electrode** for instructions.
16. Ensure cabinet panels are reinstalled when complete.
17. Burner plate torque must be re-checked after bringing the boiler up to operating temperature. Use caution around hot surfaces.

Removing and Cleaning Flame Rod

This boiler uses an ionization electrode flame rod for proof of burner flame during light-off and normal run. Replacement of the flame rod is part of the annual maintenance.

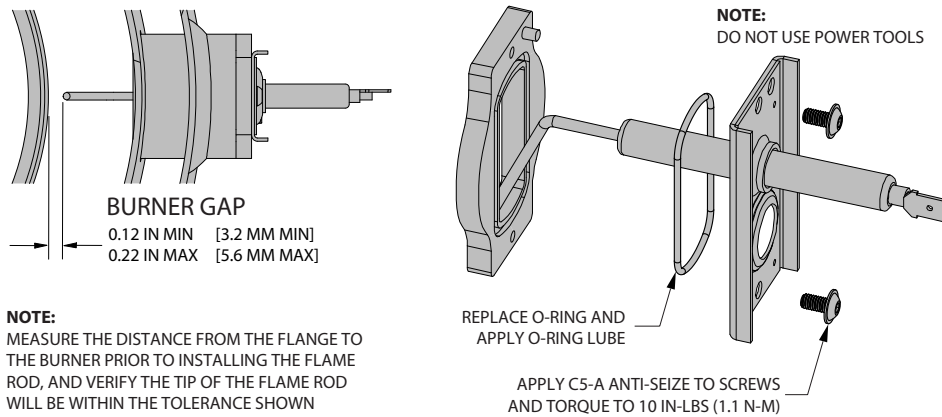

FIGURE 25 - FLAME ROD DETAIL

1. Replace the flame rod immediately if any of the following are observed:
 - The electrode geometry is warped
 - Severe corrosion is present on the electrode
 - The porcelain or insulator area of the flame rod is cracked, chipped, or damaged
 - The spade terminal is corroded
2. Dust, carbon build up, or minor rust on the electrode surface can reduce the reliability of the flame rod. Clean the electrode using only a grade #00 very fine steel wool pad as needed, replace annually. Refer to Figure 28 for part number.
3. Do not re-use o-rings, replace with new and apply o-ring lube. Refer to **Figure 28** for part numbers.
4. Reinstall the flame rod in the combustion chamber. Apply C5-A copper anti-sieze to both screws and torque to 10 in-lbs (1.1 N-m). Verify the electrode is a minimum of 0.12" (3.2mm) and no more than 0.22" (5.6 mm) from the surface of the burner head.

⚠ WARNING

Never use open flame or other sources of ignition to check for gas leaks.

Ensure boiler is off and cooled, with proper lockout - tagout per local codes prior to service and maintenance.

⚠ CAUTION

All information in this manual is for reference and guidance purposes, and does not substitute for required professional training, conduct, and strict adherence to applicable jurisdictional/professional codes and regulations.

Use caution when using any cleaning solutions. Refer to local regulations for proper cleaning solution disposal.

Do not allow dust or dirt to accumulate around the boiler.

⚠ WARNING

Never use open flame or other sources of ignition to check for gas leaks.

Follow proper safety precautions when using a ladder.

⚠ CAUTION

All information in this manual is for reference and guidance purposes, and does not substitute for required professional training, conduct, and strict adherence to applicable jurisdictional/professional codes and regulations.

All maintenance procedures should be completed by trained personnel. Appropriate training and instructions are available through your local Fulton Representative.

In order to meet warranty conditions, ensure all appropriate maintenance activities are performed.

Electrode O-rings must not be reused. O-rings are designed for one-time use only.

Using nuts and washers not provided by Fulton can lead to flue gas leakage and cause damage to the studs.

Servicing the Direct Spark Ignition Electrode

Replacement of the ignition electrode assembly is part of annual maintenance. Refer to **Figure 26** and adhere to the following:

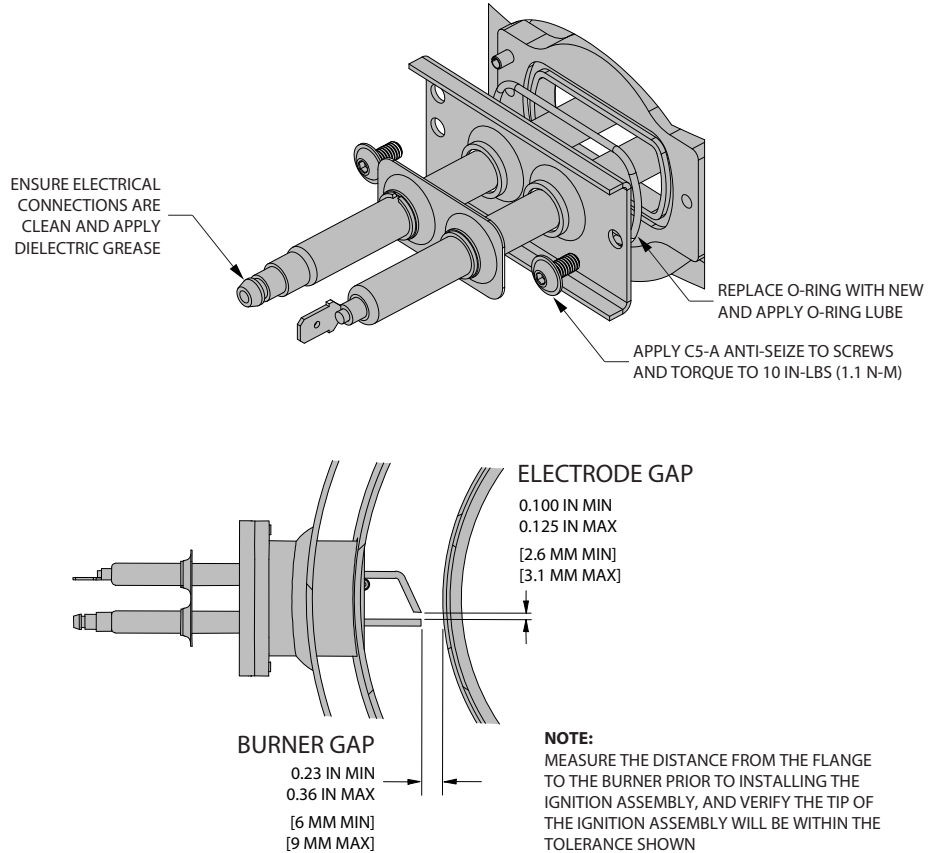

FIGURE 26 - IGNITION ELECTRODE DETAIL

1. Remove ignition electrode assembly (ignitor). Visually check that the insulators are clean. If worn, or if performing annual maintenance, replace with new. Refer to **Figure 28** for part number.
2. Verify with calibrated calipers that the gap between electrodes is greater than 0.100" (2.6 mm) and less than 0.125" (3.1 mm).
3. Do not re-use the o-ring. Replace with new and apply o-ring lube. Refer to **Figure 28** for part number.
4. Ensure electrical connections are clean and apply dielectric grease.
5. Install the ignitor. Apply C5-A copper anti-seize compound to both ignitor screws and tighten in place using a torque screwdriver to 10 in-lbs (1.1 N-m). Use caution when installing screws, cross threading or over tightening can result in stripping screws, snapping screw heads and damaging pre-tapped threading. Never use power tools to install igniter screws.

6. Verify the ignition position relative to the burner head:
 - The electrode must not be contacting the burner head.
 - The two electrodes must not be touching.
 - The burner to ignition electrode ignition gap tolerance is 0.23" (6 mm) to 0.36" (9 mm).

After All Repairs and Maintenance

1. Perform all Safety Checks as described in the **Operation** section.
 2. Fire the boiler and perform a full combustion verification. Make adjustments as necessary. Refer to Table 8 in the Operation section.
 3. Complete the "Installation and Operation Report" or "Annual Maintenance Checklist" and retain in the boiler's service history records.
- *NOTE: Accurate and complete combustion and maintenance records detailing compliance with the Installation, Operation and Maintenance manual must be produced for warranty consideration.*

Parts Diagrams

- *NOTE: Parts diagrams are for reference only. Fulton practices continuous product improvement and reserves the right to change or substitute parts without notice.*

WARNING

Never use open flame or other sources of ignition to check for gas leaks.

Ensure boiler is off and cooled, with proper lockout - tagout per local codes prior to service and maintenance.

CAUTION

All information in this manual is for reference and guidance purposes, and does not substitute for required professional training, conduct, and strict adherence to applicable jurisdictional/professional codes and regulations.

Use caution when using any cleaning solutions. Refer to local regulations for proper cleaning solution disposal.

Do not allow dust or dirt to accumulate around the boiler.

ITEM	PART NUMBER	DESCRIPTION	QTY	ITEM	PART NUMBER	DESCRIPTION	QTY
1	2-12-420007-42	WATER INLET & OUTLET DRESSER PLATE GASKET	2	23	2-45-315012	CAT 5E ETHERNET PASSTHROUGH	1
2	2-12-420008	PUSH IN BUMPER	2	24	2-45-420012	1" NYLON CORD CONNECTOR LOCKNUT	2
3*	2-12-420009-42	EXE 399/500 - EXHAUST DRESSER PLATE GASKET	1	25	2-45-420014	1" NPT CORD GRIP WASHER	1
	2-12-420010-42	EXE 650/750 - EXHAUST DRESSER PLATE GASKET		26	5-10-420017-42	CORD GRIP BRACKET	2
4	2-12-420011-42	GAS TRAIN DRESSER PLATE GASKET	1	27	5-10-420018-42	CONDENSATE DRAIN DRESSER PLATE	1
5	2-12-420013-42	AIR INLET DRESSER PLATE GASKET	1	28	5-10-420019-42	WATER INLET & OUTLET DRESSER PLATE	2
6	2-12-420014-42	CONDENSATE DRAIN DRESSER PLATE GASKET	1	29*	5-10-420021-42	EXE 399/500 - EXHAUST DRESSER PLATE	1
7	2-22-000033	10-24 X 1/2" UNC HEX HEAD SELF TAPPING SCREW	41		5-10-420020-42	EXE 650/750 - EXHAUST DRESSER PLATE	
8	2-22-315100-31	M6-1 x 16mm FLANGED BUTTON HEAD CAP SCREW	28	30	5-10-420022-42	GAS TRAIN DRESSER PLATE	1
9	2-22-315105-31	M6-1 x 40mm FLANGED BUTTON HEAD CAP SCREW	8	31*	5-10-420023-42	EXE 399/500 - CABINET TO PV BRACKET	1
10	2-22-420012	13mm O.D. X 15mm ALUM. SPACER	4		5-10-420024-42	EXE 650/750 - CABINET TO PV BRACKET	
11	2-22-420017	M6-1 x 12mm FLANGED BUTTON HEAD CAP SCREW	4	32	5-10-420032-42	AIR INLET DRESSER PLATE	1
12	2-22-420018	M4 X .7 X 50MM SOCKET HEAD CAP SCREW	4	33	5-10-420033-42	CABINET FAN AIR DIVERTER	1
13	2-22-420019	M4 SPLIT LOCK WASHER	4	34	5-10-420034-42	LOW VOLTAGE REAR ACCESS COVER	1
14	2-22-420020	M4 X .7 X 6mm ZINC PLATED THREAD FORMING SCREW	2	35	5-21-420001-42	BASE PAN ASSEMBLY	1
15	2-30-420008	RECESSED PULL HANDLE	1	36	5-21-420002-42	RIGHT SIDE PANEL ASSEMBLY	1
16	2-40-420001	HMI	1	37	5-21-420003-42	CABINET BACK PANEL ASSEMBLY	1
17	2-40-420013-42	BI-METAL TEMPERATURE SENSOR	1	38	5-21-420004-42	FRONT PANEL ASSEMBLY	1
18	2-45-000022	BLACK 3 POSITION SWITCH, 2 SINGLE POLE, NO CONTACTS	1	39	5-21-420005-42	LEFT SIDE PANEL ASSEMBLY	1
19	2-45-000053	7/8" KNOCK OUT PLUG	2	40	5-21-420006-42	UPPER ELECTRICAL PANEL HANGER ASSEMBLY	1
20	2-45-000269	N/C CONTACT BLOCK	1	41	5-21-420007-42	LOWER ELECTRICAL PANEL HANGER ASSEMBLY	1
21	2-45-000300	N/O CONTACT BLOCK	1	42	5-21-420008-42	TOP PANEL ASSEMBLY	1
22	2-45-001802	.59" TO 1.00" X 1" CONDUIT NYLON STRAIN RELIEF	2	43	7-53-420001-42	CABINET FAN ASSEMBLY	1

*PARTS VARY BETWEEN XE 399/500 & XE 650/750. REFER TO BOILER SIZING FOR CORRECT PART NUMBERS.

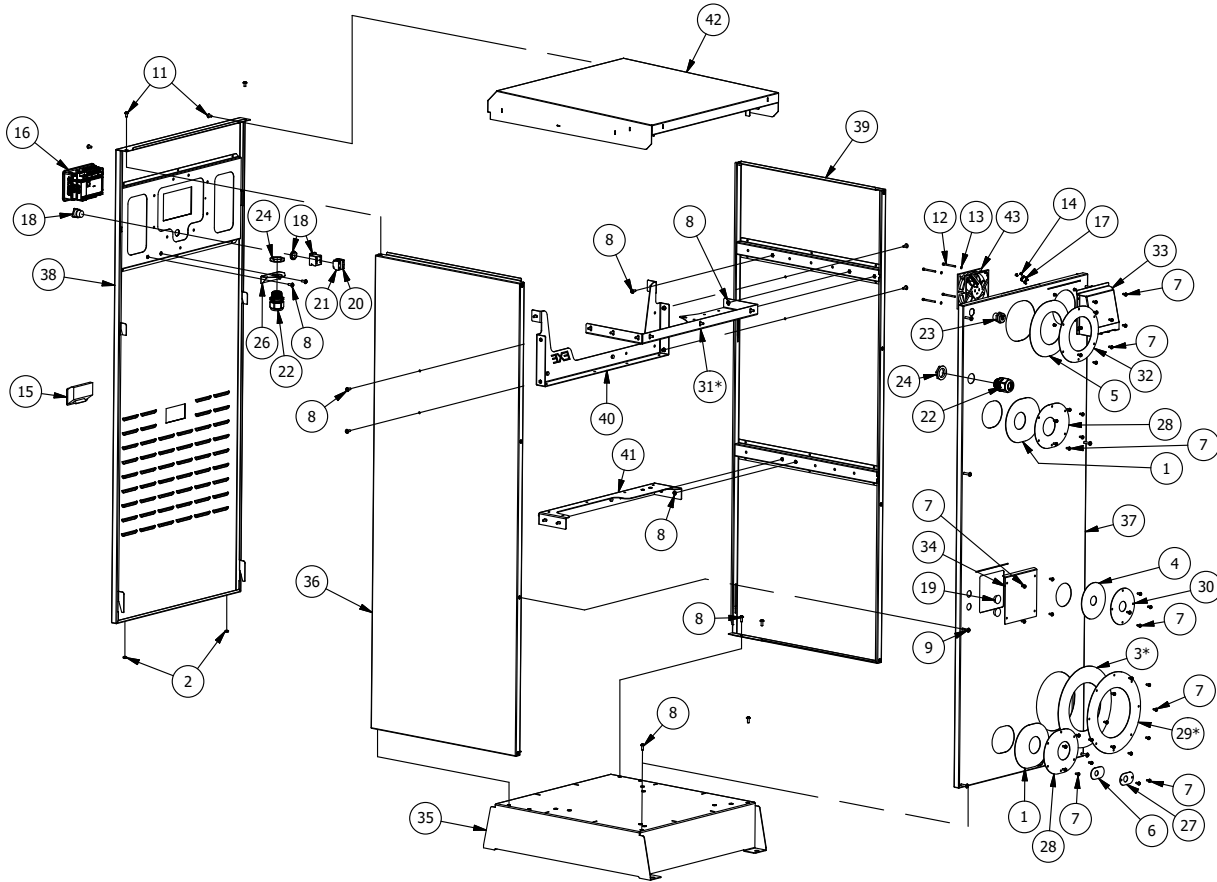

FIGURE 27 - CABINET (EXE-399 TO 750)

BILL OF MATERIAL					BILL OF MATERIAL				
ITEM	PART NUMBER	DESCRIPTION	QTY	U.O.M.	ITEM	PART NUMBER	DESCRIPTION	QTY	U.O.M.
2	2-12-000721	SPARK IGNITION/FLAME ROD O-RING	2	EA.	8	2-35-000010	1" BRASS SQUARE HEAD PLUG	1	EA.
3	2-20-420002-42	FLAME ROD	1	EA.	9	2-35-001230	1/4" BRASS SQUARE HEAD PLUG	1	EA.
4	2-20-420003-42	IGNITION ASSEMBLY	1	EA.	11	2-40-000332	WATER OUTLET TEMPERATURE SENSOR	1	EA.
6	2-22-420008	M4-.7 X 8mm 18-8 SS BUTTON HEAD CAP SCREW	4	EA.	12	2-40-000333	WATER INLET/FLUE GAS TEMPERATURE SENSOR	2	EA.
7	2-22-420027	18-8 SLOTTED SPRING PIN	1	EA.	13	2-40-420003	LOW WATER PROBE 50mm IMMERSION LENGTH	1	EA.
					13	7-53-420002-42	CONDENSATE FLOAT SWITCH WITH HARNESS	1	EA.

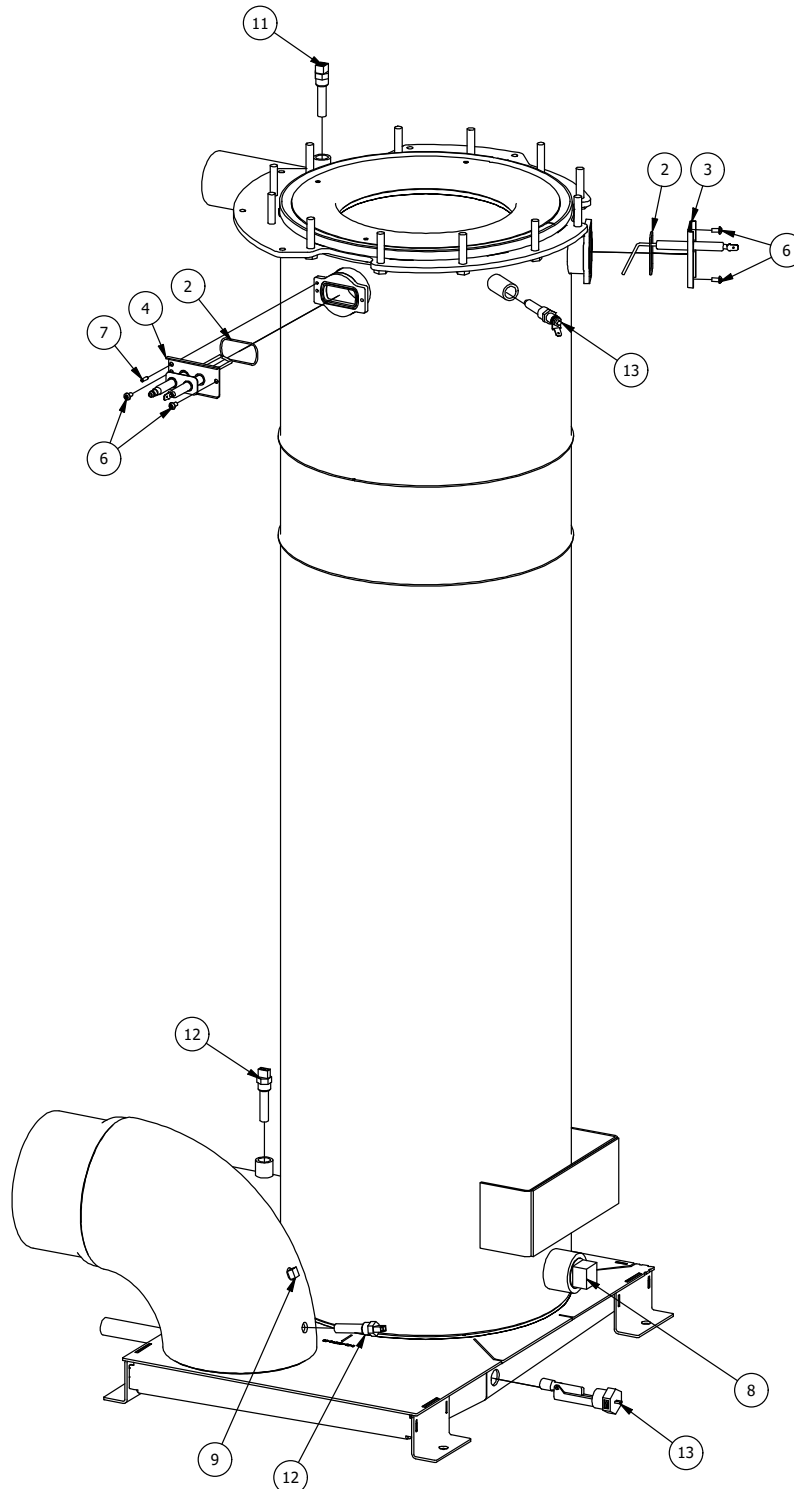
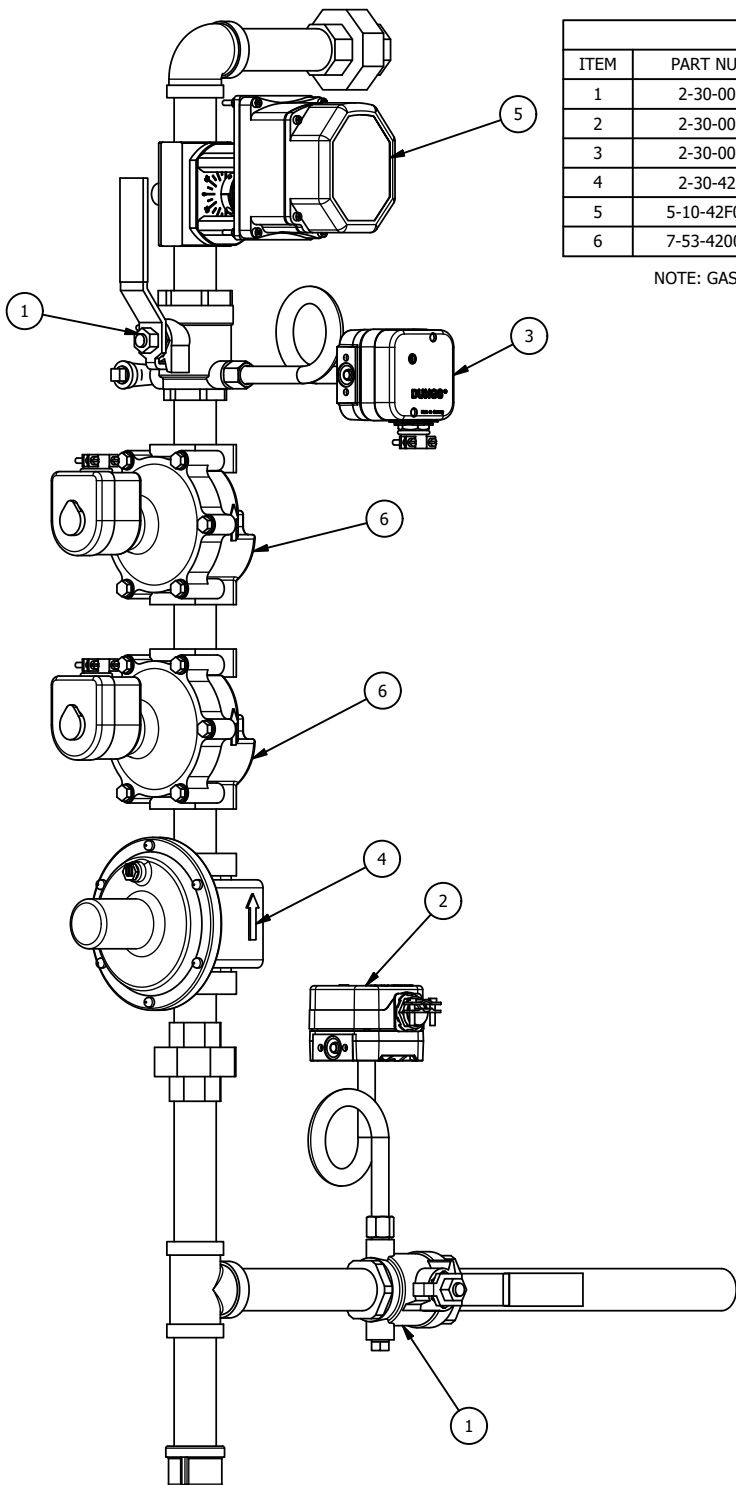

FIGURE 28 - INSTRUMENTATION AND DEVICES (EXE-399 TO 750)



BILL OF MATERIAL				
ITEM	PART NUMBER	DESCRIPTION	QTY	U.O.M.
1	2-30-000113	1" UL GAS BALL VALVE W/ DUAL SIDE TAPS	2	EA.
2	2-30-005095	LOW GAS PRESSURE SWITH 1-20" W.C.	1	EA.
3	2-30-005096	HIGH GAS PRESSURE SWITCH 1-20" W.C.	1	EA.
4	2-30-420000	GAS REGULATOR	1	EA.
5	5-10-42F037-42	1" FULL PORT BUTTERFLY VALVE / SERVO ASSEMBLY	1	EA.
6	7-53-420000-42	GAS VALVE WITH HARNESS	1	EA.

NOTE: GAS PRESSURE SWITCHES NOT USED ON UNITS WITHOUT CSD-1 COMPLIANCE

FIGURE 29 - GAS TRAIN (EXE-399 TO 750)

BILL OF MATERIAL				BILL OF MATERIAL			
ITEM	PART NUMBER	DESCRIPTION	QTY	ITEM	PART NUMBER	DESCRIPTION	QTY
1	2-40-000134	11 PIN RELAY BASE	2	11	2-45-000583	30 AMP FUSE HOLDER	1
2	2-40-420000	FLAME SAFEGUARD	1	12	2-45-000607	2 POLE JUMPER	2
3	2-40-420005-42	24VDC POWER SUPPLY	1	13	2-45-000608	3 POLE JUMPER	2
4	2-40-420016	120 VAC TO 24 VAC TRANSFORMER	1	14	2-45-000914	WIRE PLUG CONNECTION SET	1
5	2-40-420407	FULTON HI/LO WATER RELAY	2	15	2-45-001078	2 TIER TERMINAL BLOCK	16
6	2-45-000267	10 AMP TIME DELAY J FUSE	1	16	2-45-001079	2 TIER GROUNDED TERMINAL BLOCK	4
7	2-45-000365	8 AMP FUSE KLKD	1	17	2-45-001802	CONDUIT STRAIN RELIEF	1
8	2-45-000371	FUSE HOLDER	1	18	2-45-420012	1" NYLON CORD CONNECTOR LOCKNUT	1
9	2-45-000440	TERMINAL BLOCK	6	19	2-45-420020-42	12 POSITION BARRIER STRIP	2
10	2-45-000580	FUSEBLOCK COVER	1	20	2-45-420025	BARRIER STRIP JUMPER	2
				21	5-10-420017-42	CORD GRIP BRACKET	1

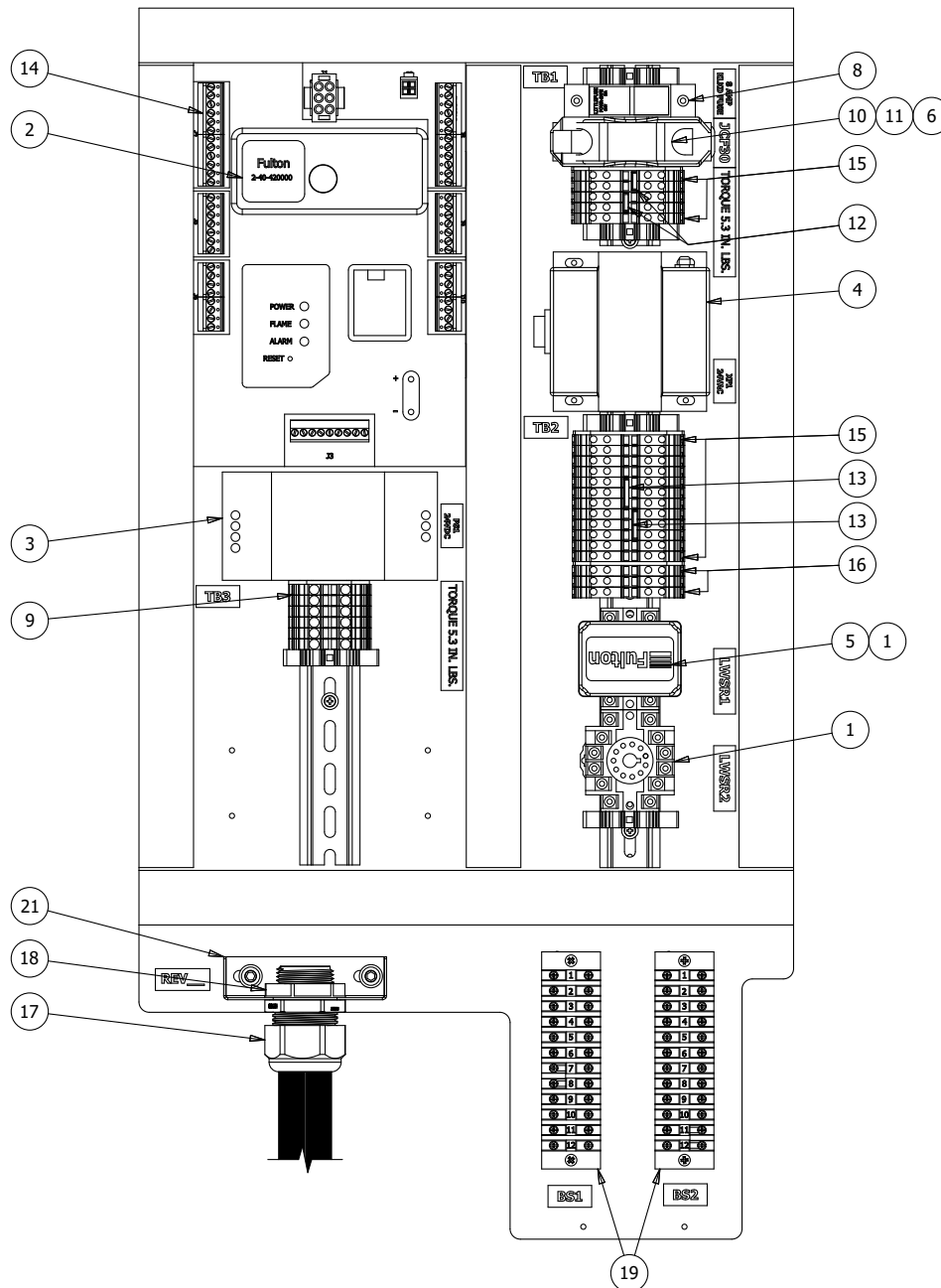
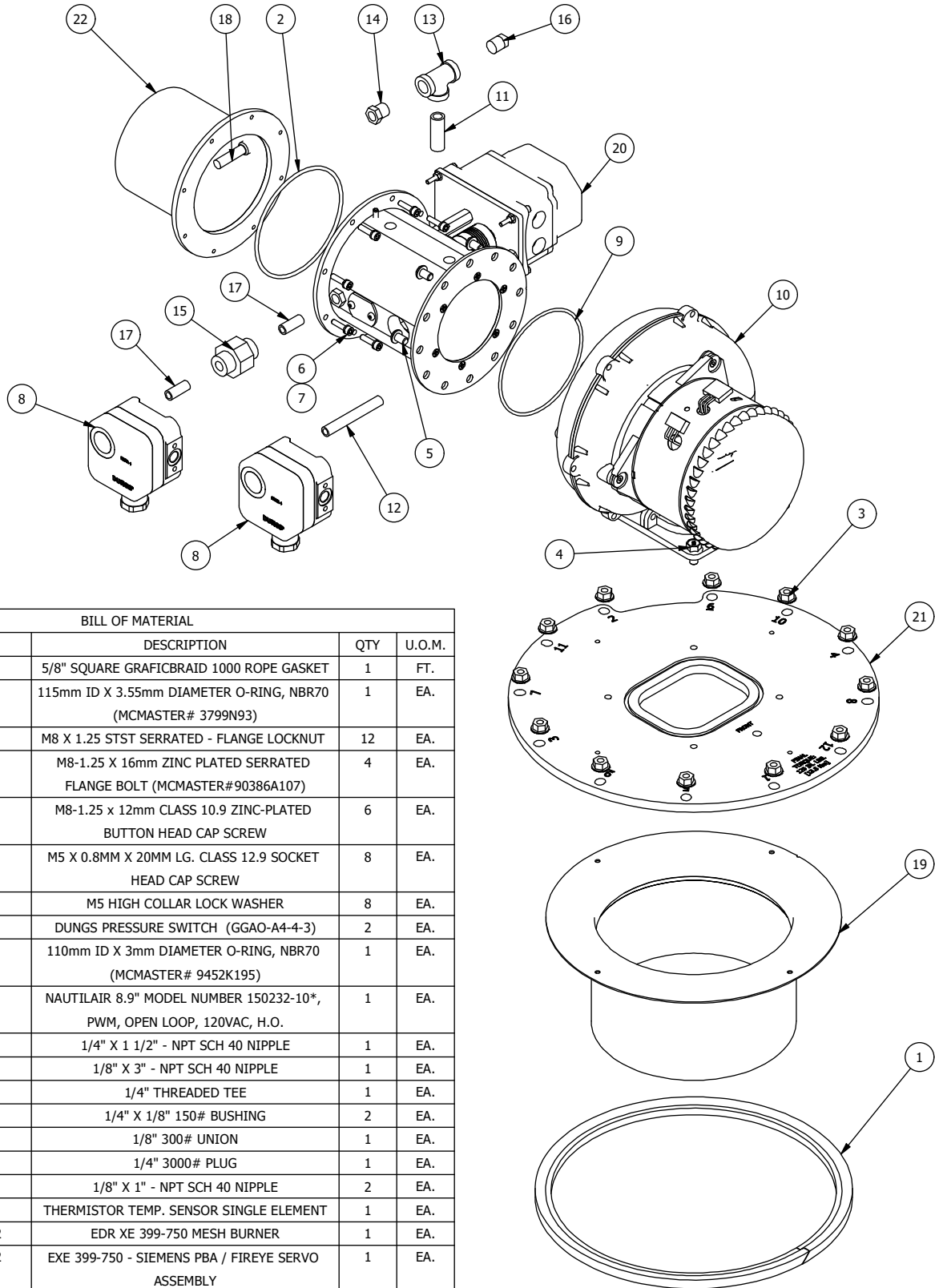

FIGURE 30 - ELECTRICAL CONTROLS (EXE-399 TO 750)



BILL OF MATERIAL				
ITEM	PART NUMBER	DESCRIPTION	QTY	U.O.M.
1	2-12-000286	5/8" SQUARE GRAFICBRAID 1000 ROPE GASKET	1	FT.
2	2-12-420004	115mm ID X 3.55mm DIAMETER O-RING, NBR70 (MCMMASTER# 3799N93)	1	EA.
3	2-22-420000	M8 X 1.25 STST SERRATED - FLANGE LOCKNUT	12	EA.
4	2-22-420001	M8-1.25 X 16mm ZINC PLATED SERRATED FLANGE BOLT (MCMMASTER#90386A107)	4	EA.
5	2-22-420002	M8-1.25 x 12mm CLASS 10.9 ZINC-PLATED BUTTON HEAD CAP SCREW	6	EA.
6	2-22-420023	M5 X 0.8MM X 20MM LG. CLASS 12.9 SOCKET HEAD CAP SCREW	8	EA.
7	2-22-420024	M5 HIGH COLLAR LOCK WASHER	8	EA.
8	2-30-001266	DUNGS PRESSURE SWITCH (GGAO-A4-4-3)	2	EA.
9	2-30-071000	110mm ID X 3mm DIAMETER O-RING, NBR70 (MCMMASTER# 9452K195)	1	EA.
10	2-30-420700	NAUTILAIR 8.9" MODEL NUMBER 150232-10*, PWM, OPEN LOOP, 120VAC, H.O.	1	EA.
11	2-35-000096	1/4" X 1 1/2" - NPT SCH 40 NIPPLE	1	EA.
12	2-35-000112	1/8" X 3" - NPT SCH 40 NIPPLE	1	EA.
13	2-35-000204	1/4" THREADED TEE	1	EA.
14	2-35-000263	1/4" X 1/8" 150# BUSHING	2	EA.
15	2-35-000280	1/8" 300# UNION	1	EA.
16	2-35-000306	1/4" 3000# PLUG	1	EA.
17	2-35-000360	1/8" X 1" - NPT SCH 40 NIPPLE	2	EA.
18	2-40-000333	THERMISTOR TEMP. SENSOR SINGLE ELEMENT	1	EA.
19	2-40-420751-42	EDR XE 399-750 MESH BURNER	1	EA.
20	5-10-42F041-42	EXE 399-750 - SIEMENS PBA / FIREYE SERVO ASSEMBLY	1	EA.
21	5-10-420715-42	EXE 399-750 BURNER TOP PLATE ASSEMBLY	1	EA.
22	5-21-420009-42	EXE 399-750 - AIR INTAKE ADAPTER ASSEMBLY	1	EA.

FIGURE 31 - BURNER AND PRE-MIX ASSEMBLY (EXE-399 TO 750)

Troubleshooting

Use the following table as a guide to troubleshooting your boiler.

PROBLEM	CAUSE	CHECK
No Power / Control Does not Illuminate	Power / Wiring / Connections	<p>Check fusing and replace as necessary.</p> <p>Cycle power to the boiler.</p> <p>Measure incoming voltage to boiler and verify it is in compliance with 120VAC requirements.</p> <p>Verify control power supply voltage.</p> <p>Verify all power plugs are fastened securely to control devices.</p> <p>Verify that the display mounting clips are not over tightened.</p> <p>Verify wiring between terminal blocks, power supplies and control devices.</p>
Nuisance Manual Reset High Temperature Limit Lockouts	Controller/Settings	<p>Verify the setting on the Manual Reset High Limit (MRHL), it must always be higher than the sum of the temperature setpoint plus off hysteresis value. The factory default setting is 210°F.</p> <p>Check the supply temperature setpoint setting parameter in the boiler control or Building Management System setpoint signal where applicable. The closer the setpoint setting is to the MRHL setting, the higher the likelihood of a lockout.</p>
	Installation	<p>Verify balancing valves (if used) have been properly commissioned.</p> <p>For modular boiler plants, ensure piping is configured reverse return where the first boiler in is the last boiler out. If the piping configuration is not reverse return, balancing valves should be installed and properly commissioned to ensure each boiler is receiving relatively equal water flow.</p> <p>Verify the boiler is receiving enough flow at the current heat demand for the given hydronic fluid type and desired delta-T. If calibrated flow meters are not available, flow rate can be approximated by calculation by observing the delta-T across the boiler heat exchanger at a given firing rate. See the Fulton "Calculating Flow Rate" Engineering Guide for more details.</p>
Boiler Excessively Cycling	Controller/Software	<p>Consult Fulton technical support to verify the latest software version is installed on the PURE Control.</p> <p>Verify boiler is configured for automatic operation.</p> <p>Verify temperature setpoint and on/off hysteresis settings are appropriate at each boiler. A tighter hysteresis band will increase cycling, relax (increase) this band to reduce cycling.</p> <p>Verify PID settings are appropriate for boiler application. Note that there are different PID settings for Local and for Lead/Lag operation. Verify these settings are correct and matching on each boiler installed.</p> <p>If a Building Automation is commanding temperature setpoint to the boiler(s), ensure that any setpoint changes are infrequent and slowly stepped in small increments/decrements. Rapid changes in temperature setpoint may cause boiler short cycling.</p>

PROBLEM	CAUSE	CHECK
Main Flame Failure	Maintenance	<p>Verify combustion parameters at all combustion points. Adjust as necessary.</p> <p>Verify sufficient supply gas pressure within the requirements of the data plate at the rear of the boiler. Ensure gas pressure does not drop more than 15% between static (idle) and dynamic (high fire).</p> <p>Verify manifold gas pressure is within the specified requirements. Refer to the factory Test Fire Report included with the boiler. Note: Test Fire Report parameters are used as a reference point, site conditions will ultimately dictate what parameters are appropriate for safe and reliable operation.</p> <p>Inspect burner, clean according to maintenance instructions if dirty.</p> <p>Verify flame rod wiring and operation; replace as needed.</p> <p>Using a manometer, measure the draft pressure at the boiler flue gas exhaust outlet connection during idle, trial for ignition, low fire and high fire. At all conditions the draft pressure must be within the limits specified in Table 4.</p> <p>Inspect the combustion air intake termination. Ensure it is not obstructed by ice, snow, or debris. Ensure the intake termination is not subjected to high wind.</p> <p>Inspect the flue gas exhaust termination. Ensure it is not obstructed by ice, snow, or debris. Ensure the flue gas exhaust termination is not subjected to high wind.</p> <p>Ensure Flue Gas Recirculation (FGR) is not occurring by visually witnessing the interaction of the exhaust and intake terminations during boiler main flame run. FGR will be evidenced by a vapor plume in the immediate vicinity of the intake termination. If occurring, this must be immediately corrected.</p> <p>Possible solutions for FGR include:</p> <ul style="list-style-type: none"> • Removing the exhaust termination rain cap (if installed) • Installing an exhaust termination velocity cone • Increasing the height of the exhaust termination • Increasing the horizontal separation of the intake to the exhaust termination <p>Verify the boiler room is at a neutral pressure relative to the outdoors.</p> <p>Verify no other mechanical equipment intake or exhaust is installed near the boiler combustion air intake, such as other boilers, water heaters, air handling equipment, cogen units and or cooling towers.</p>
CPU Error Displayed	Electrical/Wiring	<p>Verify all modules clipped into the back of display are fastened completely and securely.</p> <p>Replace CPU module and/or display.</p>
Temperature(s) Not Displaying Properly	Controller/Settings	<p>Reset retained tags and reload user defaults.</p> <p>If an update was recently performed, verify the correct software type for the boiler model and hardware was installed.</p>
	Electrical/Wiring	<p>Verify wiring to and from appropriate devices.</p> <p>Replace sensor with a known working sensor to determine possibility of failed sensor.</p>

PROBLEM	CAUSE	CHECK
Errors During Program Update	Controller/Settings	<p>Refer to Downloading A Program to The PLC of the PURE Control User Manual for details regarding program updates.</p> <p>A 16GB or larger flash drive formatted to FAT32 only is required when performing a software update.</p> <p>If a "Version Mismatch: UniLogic/UniStream Firmware" screen is prompted while performing the program update, continue performing the update.</p> <p>If further issues are experienced, contact Fulton technical support</p>
No SD Card Error	Controller/Settings	<p>Install/Replace microSD card with a capacity of 4GB or larger.</p> <p>Reference PURE Control User Manual for more information on microSD card.</p>
Burner Harmonic or Resonance	Maintenance	<p>Navigate to the Commissioning screen within the Tech Tools menu and run the boiler at each point while using a manometer and combustion analyzer to verify parameters adhere to Table 8. Adjust and verify as necessary.</p> <p>Inspect burner, clean according to maintenance instructions if dirty.</p>
Blower does not start unless power cycled	Installation/ Maintenance	<p>A manual lockout of the blower is a required safe shutdown as a result of an ambient air overtemperature condition. To reset the blower, cycle power to the boiler. To prevent lockouts of the blower ensure the room temperature and temperature inside the boiler cabinet does not exceed 104°F (40°C).</p>
High Condensate Alarm	Installation/ Maintenance	<p>This alarm is an automatic reset and boiler operation will resume when the condensate pan drains and the float switch position drops.</p> <p>Verify the condensate drain trap is installed in the correct direction and orientation. Refer to the Installation section of this manual.</p> <p>Verify the boiler is installed on a level surface. If the boiler is found to be out of level, disconnect all piping and use metal shims to level the boiler. Re-install piping when completed.</p> <p>Verify the minimum slope is present on all drain lines, and the trap and drain lines are free and clear of debris.</p> <p>Remove the float switch and verify it is operating properly and not stuck in the upward position. Re-install in the correct orientation.</p>
Condensate Sensor Not Detected Alarm	Maintenance	<p>Verify all wiring and harnesses from the control to the float switch are connected and tight.</p> <p>Inspect the 250 ohm resistor and verify it is seated properly.</p> <p>To verify operation, remove the float switch and test resistance with a DMM. An open switch (down position) is approximately 250 ohm, and a closed switch (up position) is approximately 0 ohm.</p>

PROBLEM	CAUSE	CHECK
Air Switch Not Proven Alarm	Controller/Settings	<p>Open the Alarm history, tap the row # of the air switch (AS) alarm, and tap "Info" to view detailed information. Document the burner stage and firing rate the alarm is occurring.</p> <p>Navigate to the Commissioning screen within the Tech Tools menu and run the boiler at each point while using a manometer to verify the manifold pressure meets Table 8 at all combustion points. If the manifold is not met at a point, first increase the manifold pressure, then correct the air/fuel ratio to obtain the proper O2%.</p> <p>If AS alarms are repeatedly occurring at low firing rates, ensure the minimum blower discharge pressure listed in Table 8 is met. For high wind areas, long or complex venting arrangements, consider increasing P1 blower discharge pressure then re-tune manifold and O2%.</p>
	Installation/Maintenance	<p>Verify combustion air intake (intake) and flue gas venting (vent) arrangements comply with this manual. Pay particular attention to termination styles, location(s) and separation.</p> <p>Verify the boiler room pressure is neutral relative to the outdoors. The boiler room must not be under a negative pressure.</p> <p>Inspect intake and vent for obstructions. Use a manometer to verify the sum of both intake and vent pressures complies with Table 4.</p>
	Electrical/Wiring	<p>Verify the AS setting is -1.0 "W.C.</p> <p>Verify switch operation. Verify wiring to the switch and J6.2 on the flame safeguard.</p>

INTRODUCTION

1

INSTALLATION

2

OPERATION

3

MAINTENANCE

4

SERVICE DOCUMENTS

5

PAGE INTENTIONALLY LEFT BLANK



PRE-COMMISSIONING INSTALLATION CHECKLIST

NOTE:
TO BE COMPLETED BY INSTALLING CONTRACTOR.

DATE
CONTACT NAME
BOILER MODEL

JOB SITE NAME
PHONE NUMBER
BOILER NB/SERIAL #

ELECTRICAL & COMMUNICATION:

Electrical wiring to the boiler terminated and tested?	<input type="checkbox"/> YES	<input type="checkbox"/> NO	
Voltage matches the data plate on the rear of the boiler? (120V 60Hz 1Ø)	<input type="checkbox"/> YES	<input type="checkbox"/> NO	
Control wiring for lead/lag is terminated and tested?	<input type="checkbox"/> YES	<input type="checkbox"/> NO	<input type="checkbox"/> N/A
Building automation wiring is terminated and tested?	<input type="checkbox"/> YES	<input type="checkbox"/> NO	<input type="checkbox"/> N/A

SYSTEM PIPING

All hydronic piping to the boiler is completed and leak tested?	<input type="checkbox"/> YES	<input type="checkbox"/> NO	
All hydronic piping has been fully flushed? <i>Note: Chemical cleaning must bypass the boiler; clean water flush must have strainers at the boiler inlet</i>	<input type="checkbox"/> YES	<input type="checkbox"/> NO	
Circulating pumps are wired, tested, and ready for operation?	<input type="checkbox"/> YES	<input type="checkbox"/> NO	
Motorized boiler isolation valves are wired, tested, and fully operational?	<input type="checkbox"/> YES	<input type="checkbox"/> NO	<input type="checkbox"/> N/A

FLUE GAS EXHAUST VENT AND COMBUSTION AIR INTAKE:

Flue vent meets material type and requirements detailed in the IOM?	<input type="checkbox"/> YES	<input type="checkbox"/> NO	
Flue and combustion air terminations meet minimum separation requirements and are installed to prevent flue gas recirculation?	<input type="checkbox"/> YES	<input type="checkbox"/> NO	
Condensate drain is completed and meets IOM installation requirements?	<input type="checkbox"/> YES	<input type="checkbox"/> NO	
Combustion air louvers meet minimum SQFT detailed in IOM?	<input type="checkbox"/> YES	<input type="checkbox"/> NO	<input type="checkbox"/> N/A
Mechanical draft controls are powered, tested, and fully operational?	<input type="checkbox"/> YES	<input type="checkbox"/> NO	<input type="checkbox"/> N/A

FUEL PIPING

Supply gas piping and regulators are properly sized to ensure adequate gas supply under all operating conditions? (Idle, Light Off, High Fire, etc.)	YES	NO	
Use a manometer to measure the gas pressure at the fuel train inlet:	_____ INCHES WC		
Does the measured gas pressure meet the requirement listed on the data plate on the rear of the boiler?	YES	NO	
Gas vents are individually run, properly upsized every 10 feet, and terminated to atmosphere if required by Authority Having Jurisdiction?	<input type="checkbox"/> YES	<input type="checkbox"/> NO	<input type="checkbox"/> N/A
Gas regulators installed minimum 10 feet of pipe from the boilers?	<input type="checkbox"/> YES	<input type="checkbox"/> NO	<input type="checkbox"/> N/A

SITE SIGN-OFF
PRINT NAME

DATE:
TITLE:

When complete, return a copy to your Fulton Representative and/or the service organization performing commissioning ("start-up") services.

PAGE INTENTIONALLY LEFT BLANK



ENDURA XE
INSTALLATION & OPERATION
"START-UP" REPORT

NOTE:

TO BE COMPLETED BY A FACTORY AUTHORIZED TECHNICIAN HOLDING A VALID ENDURA XE CERTIFICATE OF REGISTRATION. WARRANTY COVERAGE IS VALID ONLY IF THIS FORM IS SUCCESSFULLY COMPLETED AND RETURNED TO FULTON WITHIN TWELVE WEEKS OF START-UP.

DATE	
TECHNICIAN	
TECH. COMPANY	
TECH CERTIFICATE #	
BOILER MODEL	
NATIONAL BOARD #	

FULTON REP.	
CUSTOMER	
CONTACT NAME	
CITY, STATE	
PHONE NUMBER	
E-MAIL	

GENERAL:

Boiler room pressure (Note: Must be neutral pressure)		INCHES WC
Is the boiler configured for internal lead lag?	<input type="checkbox"/> YES	<input type="checkbox"/> NO
Boiler set point source (i.e. BMS, OAT, 4 - 20mA, Static)		

COMBUSTION AIR SUPPLY FROM BOILER ROOM ONLY:

If boiler room, what is the Upper Louver Size? (In inches)	LENGTH _____	HEIGHT _____
If boiler room, what is the Lower Louver Size?	LENGTH _____	HEIGHT _____
Combustion air louver type	<input type="checkbox"/> FIXED	<input type="checkbox"/> MOTORIZED
If motorized, are they interlocked with the boilers?	<input type="checkbox"/> YES	<input type="checkbox"/> NO <input type="checkbox"/> N/A



COMBUSTION AIR SUPPLY DUCTED DIRECTLY TO BOILER ONLY:



Combustion air intake material type (ie: PVC, Spiral Metal Duct, etc.)	
Air intake termination location	<input type="checkbox"/> ROOFTOP <input type="checkbox"/> SIDEWALL
Intake configuration	<input type="checkbox"/> INDIVIDUAL <input type="checkbox"/> COMMON
Combustion air intake ducting diameter	_____ INCHES
Combustion air intake ducting length	_____ FEET
Combustion air intake elbow quantity	45'S _____ 90'S _____
Horizontal separation between intake and exhaust termination	_____ FEET
Vertical separation between intake and exhaust termination	_____ FEET

FLUE GAS EXHAUST VENT CONFIGURATION:



























































































Flue Gas Exhaust Venting (ie: CAT II/IV, AL29 - 4C, Polypropylene or 316L SS)	
Exhaust termination location	<input type="checkbox"/> ROOFTOP <input type="checkbox"/> SIDEWALL
Exhaust configuration	<input type="checkbox"/> INDIVIDUAL <input type="checkbox"/> COMMON
Venting inside diameter	_____ INCHES
Total Venting length (Rise + Run)	_____ FEET
Vertical rise only	_____ FEET
Elbows quantity	45'S _____ 90'S _____
If common vented, is an exhaust fan installed?	<input type="checkbox"/> YES <input type="checkbox"/> NO
What Is The Set Pressure Of The Fan?	_____ INCHES WC
Common vent pressure with all the boilers on at...	HIGH FIRE _____ LOW FIRE _____
Does the boiler have a modulating draft damper?	<input type="checkbox"/> YES <input type="checkbox"/> NO
Does the common exhaust have a modulating draft damper?	<input type="checkbox"/> YES <input type="checkbox"/> NO

SAFETY CHECKS: Check all safeties below for proper operation and document the final settings.

DEVICE	SETTING	PASSED
Low Water Safety		
Air Switch		
Low Gas Pressure Switch		
High Gas Pressure Switch		
High Condensate Safety		
Blocked Intake Switch		

DEVICE	SETTING	PASSED
High Temperature Limit		
Temperature Controller		
Fuel Train Leak Test		
Blower Leak Test		
Burner CO Test (<100 ppm)		

COMBUSTION SETTINGS: Fuel Type is: **Natural Gas** **Propane**

FIRING POSITION:	P0 LIGHT	P1	P2	P3	P4	P5	P6	P7	P8	P9	P10 100%
Incoming Voltage											
Supply Gas Pressure (InWC)*											
Manifold Gas Pressure (InWC)*											
MV Downstream Gas (InWC)*											
Fan Discharge Pressure (InWC)*											
Wet (Analyzer) O2%											
Room Ambient Temp. °F											
Combustion Air Temp. °F											
Stack Temperature °F											
Stack Draft (InWC)*											
Main Flame Signal											

* Use only a Slack Tube® Manometer or equivalent. The use of a digital manometer is not recommended.

When complete, please keep this form with the boiler, store a record copy in a safe location, and return a copy to Fulton:

Fulton
ATTN: Service Coordinator
972 Centerville Road
Pulaski, New York 13142

Phone: (315) 298-5121 • Fax: (315) 298-6390



ENDURA XE
ANNUAL MAINTENANCE CHECKLIST

NOTE:

TO BE COMPLETED BY A FACTORY AUTHORIZED TECHNICIAN HOLDING A VALID ENDURA XE CERTIFICATE OF REGISTRATION.

DATE	
TECHNICIAN	
TECH. COMPANY	

TECH CERTIFICATE #	
BOILER MODEL	
BOILER NB/SERIAL #	

ANNUAL MAINTENANCE:

Burner head removed and visually inspected	<input type="checkbox"/>	COMPLETE
Burner head cleaned (air only)	<input type="checkbox"/>	COMPLETE
Burner head reinstalled with new gaskets	<input type="checkbox"/>	COMPLETE
Burner flange hardware torqued to spec (see Section 4 of IOM)	<input type="checkbox"/>	COMPLETE
Low water probe(s) removed, cleaned, and reinstalled	<input type="checkbox"/>	COMPLETE
Flame rod inspected and cleaned, or replaced if worn	<input type="checkbox"/>	COMPLETE
Direct spark ignition replaced with new and gap properly set	<input type="checkbox"/>	COMPLETE
Special gas vent system and condensate drains inspected	<input type="checkbox"/>	COMPLETE
Combustion air intake system inspected	<input type="checkbox"/>	COMPLETE
Safety relief valve tested, replaced if it does not fully reseal	<input type="checkbox"/>	COMPLETE
Open factory Service Bulletin(s) addressed (where applicable)	<input type="checkbox"/>	COMPLETE
Safety checks table completed		(fill in tables below)
Combustion verification completed, adjust as necessary		(fill in tables on reverse side)
Burner flange torque re-checked after bringing the boiler up to operating temperature	<input type="checkbox"/>	COMPLETE

WATER CHEMISTRY: *Verify water chemistry is within specified limits, correct where required*

pH (8.5-10.5)	_____	
Oxygen (<250 ppb)	_____	ppb
Iron/Copper (<5 ppm)	_____	ppm
Chloride (<200 ppm)	_____	ppm
Hardness (<60 ppm)	_____	ppm
Glycol %	_____	%

SAFETY CHECKS: *Check all safeties below for proper operation and document the final settings.*

DEVICE	SETTING	PASSED
Low Water Safety		
Air Switch		
Low Gas Pressure Switch		
High Gas Pressure Switch		
High Condensate Safety		
Blocked Intake Switch		

DEVICE	SETTING	PASSED
High Temperature Limit		
Temperature Controller		
Fuel Train Leak Test		
Blower Leak Test		
Burner CO Test (<100 ppm)		

COMBUSTION SETTINGS: Fuel Type is: **Natural Gas** **Propane**

FIRING POSITION:	P0 LIGHT	P1	P2	P3	P4	P5	P6	P7	P8	P9	P10 100%
Incoming Voltage	XXXX	XXXX	XXXX	XXXX	XXXX	XXXX	XXXX	XXXX	XXXX	XXXX	
Supply Gas Pressure (InWC)*			XXXX	XXXX	XXXX	XXXX	XXXX	XXXX	XXXX	XXXX	
Manifold Gas Pressure (InWC)*											
MV Downstream Gas (InWC)*	XXXX	XXXX	XXXX	XXXX	XXXX	XXXX	XXXX	XXXX	XXXX	XXXX	
Fan Discharge Pressure (InWC)*			XXXX	XXXX	XXXX	XXXX	XXXX	XXXX	XXXX	XXXX	
Wet (Analyzer) O2%											
Room Ambient Temp. °F	XXXX	XXXX	XXXX	XXXX	XXXX	XXXX	XXXX	XXXX	XXXX	XXXX	
Combustion Air Temp. °F	XXXX	XXXX	XXXX	XXXX	XXXX	XXXX	XXXX	XXXX	XXXX	XXXX	
Stack Temperature °F	XXXX	XXXX	XXXX	XXXX	XXXX	XXXX	XXXX	XXXX	XXXX	XXXX	
Stack Draft (InWC)*			XXXX	XXXX	XXXX	XXXX	XXXX	XXXX	XXXX	XXXX	
Main Flame Signal			XXXX	XXXX	XXXX	XXXX	XXXX	XXXX	XXXX	XXXX	XXXX

** Use only a Slack Tube® Manometer or equivalent. The use of a digital manometer is not recommended.*

OPERATING HISTORY

Boiler Online Hours	
Boiler Run Hours	
Boiler Cycles	
Attempted Ignitions	
Successful Ignitions	

When complete, please keep this form with the boiler and store a record copy in a safe location. Accurate and complete combustion and maintenance records detailing compliance with the Installation, Operation, and Maintenance Manual must be produced for warranty consideration. Please use photocopies or consult your local Fulton Representative for additional copies of this form.



ENDURA XE
ANNUAL MAINTENANCE CHECKLIST

NOTE:

TO BE COMPLETED BY A FACTORY AUTHORIZED TECHNICIAN HOLDING A VALID ENDURA XE CERTIFICATE OF REGISTRATION.

DATE	
TECHNICIAN	
TECH. COMPANY	

TECH CERTIFICATE #	
BOILER MODEL	
BOILER NB/SERIAL #	

ANNUAL MAINTENANCE:

Burner head removed and visually inspected	<input type="checkbox"/>	COMPLETE
Burner head cleaned (air only)	<input type="checkbox"/>	COMPLETE
Burner head reinstalled with new gaskets	<input type="checkbox"/>	COMPLETE
Burner flange hardware torqued to spec (see Section 4 of IOM)	<input type="checkbox"/>	COMPLETE
Low water probe(s) removed, cleaned, and reinstalled	<input type="checkbox"/>	COMPLETE
Flame rod inspected and cleaned, or replaced if worn	<input type="checkbox"/>	COMPLETE
Direct spark ignition replaced with new and gap properly set	<input type="checkbox"/>	COMPLETE
Special gas vent system and condensate drains inspected	<input type="checkbox"/>	COMPLETE
Combustion air intake system inspected	<input type="checkbox"/>	COMPLETE
Safety relief valve tested, replaced if it does not fully reseal	<input type="checkbox"/>	COMPLETE
Open factory Service Bulletin(s) addressed (where applicable)	<input type="checkbox"/>	COMPLETE
Safety checks table completed		(fill in tables below)
Combustion verification completed, adjust as necessary		(fill in tables on reverse side)
Burner flange torque re-checked after bringing the boiler up to operating temperature	<input type="checkbox"/>	COMPLETE

WATER CHEMISTRY: *Verify water chemistry is within specified limits, correct where required*

pH (8.5-10.5)	_____	
Oxygen (<250 ppb)	_____	ppb
Iron/Copper (<5 ppm)	_____	ppm
Chloride (<200 ppm)	_____	ppm
Hardness (<60 ppm)	_____	ppm
Glycol %	_____	%

SAFETY CHECKS: *Check all safeties below for proper operation and document the final settings.*

DEVICE	SETTING	PASSED
Low Water Safety		
Air Switch		
Low Gas Pressure Switch		
High Gas Pressure Switch		
High Condensate Safety		
Blocked Intake Switch		

DEVICE	SETTING	PASSED
High Temperature Limit		
Temperature Controller		
Fuel Train Leak Test		
Blower Leak Test		
Burner CO Test (<100 ppm)		

COMBUSTION SETTINGS: Fuel Type is: **Natural Gas** **Propane**

FIRING POSITION:	P0 LIGHT	P1	P2	P3	P4	P5	P6	P7	P8	P9	P10 100%
Incoming Voltage	▬	▬	▬	▬	▬	▬	▬	▬	▬	▬	▬
Supply Gas Pressure (InWC)*	▬	▬	▬	▬	▬	▬	▬	▬	▬	▬	▬
Manifold Gas Pressure (InWC)*	▬	▬	▬	▬	▬	▬	▬	▬	▬	▬	▬
MV Downstream Gas (InWC)*	▬	▬	▬	▬	▬	▬	▬	▬	▬	▬	▬
Fan Discharge Pressure (InWC)*	▬	▬	▬	▬	▬	▬	▬	▬	▬	▬	▬
Wet (Analyzer) O2%	▬	▬	▬	▬	▬	▬	▬	▬	▬	▬	▬
Room Ambient Temp. °F	▬	▬	▬	▬	▬	▬	▬	▬	▬	▬	▬
Combustion Air Temp. °F	▬	▬	▬	▬	▬	▬	▬	▬	▬	▬	▬
Stack Temperature °F	▬	▬	▬	▬	▬	▬	▬	▬	▬	▬	▬
Stack Draft (InWC)*	▬	▬	▬	▬	▬	▬	▬	▬	▬	▬	▬
Main Flame Signal	▬	▬	▬	▬	▬	▬	▬	▬	▬	▬	▬

** Use only a Slack Tube® Manometer or equivalent. The use of a digital manometer is not recommended.*

OPERATING HISTORY

Boiler Online Hours	▬
Boiler Run Hours	▬
Boiler Cycles	▬
Attempted Ignitions	▬
Successful Ignitions	▬

When complete, please keep this form with the boiler and store a record copy in a safe location. Accurate and complete combustion and maintenance records detailing compliance with the Installation, Operation, and Maintenance Manual must be produced for warranty consideration. Please use photocopies or consult your local Fulton Representative for additional copies of this form.



ENDURA XE
ANNUAL MAINTENANCE CHECKLIST

NOTE:

TO BE COMPLETED BY A FACTORY AUTHORIZED TECHNICIAN HOLDING A VALID ENDURA XE CERTIFICATE OF REGISTRATION.

DATE	
TECHNICIAN	
TECH. COMPANY	

TECH CERTIFICATE #	
BOILER MODEL	
BOILER NB/SERIAL #	

ANNUAL MAINTENANCE:

Burner head removed and visually inspected	<input type="checkbox"/>	COMPLETE
Burner head cleaned (air only)	<input type="checkbox"/>	COMPLETE
Burner head reinstalled with new gaskets	<input type="checkbox"/>	COMPLETE
Burner flange hardware torqued to spec (see Section 4 of IOM)	<input type="checkbox"/>	COMPLETE
Low water probe(s) removed, cleaned, and reinstalled	<input type="checkbox"/>	COMPLETE
Flame rod inspected and cleaned, or replaced if worn	<input type="checkbox"/>	COMPLETE
Direct spark ignition replaced with new and gap properly set	<input type="checkbox"/>	COMPLETE
Special gas vent system and condensate drains inspected	<input type="checkbox"/>	COMPLETE
Combustion air intake system inspected	<input type="checkbox"/>	COMPLETE
Safety relief valve tested, replaced if it does not fully reseal	<input type="checkbox"/>	COMPLETE
Open factory Service Bulletin(s) addressed (where applicable)	<input type="checkbox"/>	COMPLETE
Safety checks table completed		(fill in tables below)
Combustion verification completed, adjust as necessary		(fill in tables on reverse side)
Burner flange torque re-checked after bringing the boiler up to operating temperature	<input type="checkbox"/>	COMPLETE

WATER CHEMISTRY: *Verify water chemistry is within specified limits, correct where required*

pH (8.5-10.5)	_____	
Oxygen (<250 ppb)	_____	ppb
Iron/Copper (<5 ppm)	_____	ppm
Chloride (<200 ppm)	_____	ppm
Hardness (<60 ppm)	_____	ppm
Glycol %	_____	%

SAFETY CHECKS: *Check all safeties below for proper operation and document the final settings.*

DEVICE	SETTING	PASSED
Low Water Safety		
Air Switch		
Low Gas Pressure Switch		
High Gas Pressure Switch		
High Condensate Safety		
Blocked Intake Switch		

DEVICE	SETTING	PASSED
High Temperature Limit		
Temperature Controller		
Fuel Train Leak Test		
Blower Leak Test		
Burner CO Test (<100 ppm)		

COMBUSTION SETTINGS: Fuel Type is: **Natural Gas** **Propane**

FIRING POSITION:	P0 LIGHT	P1	P2	P3	P4	P5	P6	P7	P8	P9	P10 100%
Incoming Voltage	▬	▬	▬	▬	▬	▬	▬	▬	▬	▬	▬
Supply Gas Pressure (InWC)*	▬	▬	▬	▬	▬	▬	▬	▬	▬	▬	▬
Manifold Gas Pressure (InWC)*	▬	▬	▬	▬	▬	▬	▬	▬	▬	▬	▬
MV Downstream Gas (InWC)*	▬	▬	▬	▬	▬	▬	▬	▬	▬	▬	▬
Fan Discharge Pressure (InWC)*	▬	▬	▬	▬	▬	▬	▬	▬	▬	▬	▬
Wet (Analyzer) O2%	▬	▬	▬	▬	▬	▬	▬	▬	▬	▬	▬
Room Ambient Temp. °F	▬	▬	▬	▬	▬	▬	▬	▬	▬	▬	▬
Combustion Air Temp. °F	▬	▬	▬	▬	▬	▬	▬	▬	▬	▬	▬
Stack Temperature °F	▬	▬	▬	▬	▬	▬	▬	▬	▬	▬	▬
Stack Draft (InWC)*	▬	▬	▬	▬	▬	▬	▬	▬	▬	▬	▬
Main Flame Signal	▬	▬	▬	▬	▬	▬	▬	▬	▬	▬	▬

** Use only a Slack Tube® Manometer or equivalent. The use of a digital manometer is not recommended.*

OPERATING HISTORY

Boiler Online Hours	▬
Boiler Run Hours	▬
Boiler Cycles	▬
Attempted Ignitions	▬
Successful Ignitions	▬

When complete, please keep this form with the boiler and store a record copy in a safe location. Accurate and complete combustion and maintenance records detailing compliance with the Installation, Operation, and Maintenance Manual must be produced for warranty consideration. Please use photocopies or consult your local Fulton Representative for additional copies of this form.



ENDURA XE
ANNUAL MAINTENANCE CHECKLIST

NOTE:

TO BE COMPLETED BY A FACTORY AUTHORIZED TECHNICIAN HOLDING A VALID ENDURA XE CERTIFICATE OF REGISTRATION.

DATE	
TECHNICIAN	
TECH. COMPANY	

TECH CERTIFICATE #	
BOILER MODEL	
BOILER NB/SERIAL #	

ANNUAL MAINTENANCE:

Burner head removed and visually inspected	<input type="checkbox"/>	COMPLETE
Burner head cleaned (air only)	<input type="checkbox"/>	COMPLETE
Burner head reinstalled with new gaskets	<input type="checkbox"/>	COMPLETE
Burner flange hardware torqued to spec (see Section 4 of IOM)	<input type="checkbox"/>	COMPLETE
Low water probe(s) removed, cleaned, and reinstalled	<input type="checkbox"/>	COMPLETE
Flame rod inspected and cleaned, or replaced if worn	<input type="checkbox"/>	COMPLETE
Direct spark ignition replaced with new and gap properly set	<input type="checkbox"/>	COMPLETE
Special gas vent system and condensate drains inspected	<input type="checkbox"/>	COMPLETE
Combustion air intake system inspected	<input type="checkbox"/>	COMPLETE
Safety relief valve tested, replaced if it does not fully reseal	<input type="checkbox"/>	COMPLETE
Open factory Service Bulletin(s) addressed (where applicable)	<input type="checkbox"/>	COMPLETE
Safety checks table completed		(fill in tables below)
Combustion verification completed, adjust as necessary		(fill in tables on reverse side)
Burner flange torque re-checked after bringing the boiler up to operating temperature	<input type="checkbox"/>	COMPLETE

WATER CHEMISTRY: *Verify water chemistry is within specified limits, correct where required*

pH (8.5-10.5)	_____	
Oxygen (<250 ppb)	_____	ppb
Iron/Copper (<5 ppm)	_____	ppm
Chloride (<200 ppm)	_____	ppm
Hardness (<60 ppm)	_____	ppm
Gylcol %	_____	%

SAFETY CHECKS: *Check all safeties below for proper operation and document the final settings.*

DEVICE	SETTING	PASSED
Low Water Safety		
Air Switch		
Low Gas Pressure Switch		
High Gas Pressure Switch		
High Condensate Safety		
Blocked Intake Switch		

DEVICE	SETTING	PASSED
High Temperature Limit		
Temperature Controller		
Fuel Train Leak Test		
Blower Leak Test		
Burner CO Test (<100 ppm)		

COMBUSTION SETTINGS: Fuel Type is: **Natural Gas** **Propane**

FIRING POSITION:	P0 LIGHT	P1	P2	P3	P4	P5	P6	P7	P8	P9	P10 100%
Incoming Voltage	▬	▬	▬	▬	▬	▬	▬	▬	▬	▬	▬
Supply Gas Pressure (InWC)*	▬	▬	▬	▬	▬	▬	▬	▬	▬	▬	▬
Manifold Gas Pressure (InWC)*	▬	▬	▬	▬	▬	▬	▬	▬	▬	▬	▬
MV Downstream Gas (InWC)*	▬	▬	▬	▬	▬	▬	▬	▬	▬	▬	▬
Fan Discharge Pressure (InWC)*	▬	▬	▬	▬	▬	▬	▬	▬	▬	▬	▬
Wet (Analyzer) O2%	▬	▬	▬	▬	▬	▬	▬	▬	▬	▬	▬
Room Ambient Temp. °F	▬	▬	▬	▬	▬	▬	▬	▬	▬	▬	▬
Combustion Air Temp. °F	▬	▬	▬	▬	▬	▬	▬	▬	▬	▬	▬
Stack Temperature °F	▬	▬	▬	▬	▬	▬	▬	▬	▬	▬	▬
Stack Draft (InWC)*	▬	▬	▬	▬	▬	▬	▬	▬	▬	▬	▬
Main Flame Signal	▬	▬	▬	▬	▬	▬	▬	▬	▬	▬	▬

** Use only a Slack Tube® Manometer or equivalent. The use of a digital manometer is not recommended.*

OPERATING HISTORY

Boiler Online Hours	▬
Boiler Run Hours	▬
Boiler Cycles	▬
Attempted Ignitions	▬
Successful Ignitions	▬

When complete, please keep this form with the boiler and store a record copy in a safe location. Accurate and complete combustion and maintenance records detailing compliance with the Installation, Operation, and Maintenance Manual must be produced for warranty consideration. Please use photocopies or consult your local Fulton Representative for additional copies of this form.



ENDURA XE
ANNUAL MAINTENANCE CHECKLIST

NOTE:

TO BE COMPLETED BY A FACTORY AUTHORIZED TECHNICIAN HOLDING A VALID ENDURA XE CERTIFICATE OF REGISTRATION.

DATE	
TECHNICIAN	
TECH. COMPANY	

TECH CERTIFICATE #	
BOILER MODEL	
BOILER NB/SERIAL #	

ANNUAL MAINTENANCE:

Burner head removed and visually inspected	<input type="checkbox"/>	COMPLETE
Burner head cleaned (air only)	<input type="checkbox"/>	COMPLETE
Burner head reinstalled with new gaskets	<input type="checkbox"/>	COMPLETE
Burner flange hardware torqued to spec (see Section 4 of IOM)	<input type="checkbox"/>	COMPLETE
Low water probe(s) removed, cleaned, and reinstalled	<input type="checkbox"/>	COMPLETE
Flame rod inspected and cleaned, or replaced if worn	<input type="checkbox"/>	COMPLETE
Direct spark ignition replaced with new and gap properly set	<input type="checkbox"/>	COMPLETE
Special gas vent system and condensate drains inspected	<input type="checkbox"/>	COMPLETE
Combustion air intake system inspected	<input type="checkbox"/>	COMPLETE
Safety relief valve tested, replaced if it does not fully reseal	<input type="checkbox"/>	COMPLETE
Open factory Service Bulletin(s) addressed (where applicable)	<input type="checkbox"/>	COMPLETE
Safety checks table completed		(fill in tables below)
Combustion verification completed, adjust as necessary		(fill in tables on reverse side)
Burner flange torque re-checked after bringing the boiler up to operating temperature	<input type="checkbox"/>	COMPLETE

WATER CHEMISTRY: *Verify water chemistry is within specified limits, correct where required*

pH (8.5-10.5)	_____	
Oxygen (<250 ppb)	_____	ppb
Iron/Copper (<5 ppm)	_____	ppm
Chloride (<200 ppm)	_____	ppm
Hardness (<60 ppm)	_____	ppm
Glycol %	_____	%

SAFETY CHECKS: *Check all safeties below for proper operation and document the final settings.*

DEVICE	SETTING	PASSED
Low Water Safety		
Air Switch		
Low Gas Pressure Switch		
High Gas Pressure Switch		
High Condensate Safety		
Blocked Intake Switch		

DEVICE	SETTING	PASSED
High Temperature Limit		
Temperature Controller		
Fuel Train Leak Test		
Blower Leak Test		
Burner CO Test (<100 ppm)		

COMBUSTION SETTINGS: Fuel Type is: **Natural Gas** **Propane**

FIRING POSITION:	P0 LIGHT	P1	P2	P3	P4	P5	P6	P7	P8	P9	P10 100%
Incoming Voltage	▣	▣	▣	▣	▣	▣	▣	▣	▣	▣	▣
Supply Gas Pressure (InWC)*	▣	▣	▣	▣	▣	▣	▣	▣	▣	▣	▣
Manifold Gas Pressure (InWC)*	▣	▣	▣	▣	▣	▣	▣	▣	▣	▣	▣
MV Downstream Gas (InWC)*	▣	▣	▣	▣	▣	▣	▣	▣	▣	▣	▣
Fan Discharge Pressure (InWC)*	▣	▣	▣	▣	▣	▣	▣	▣	▣	▣	▣
Wet (Analyzer) O2%	▣	▣	▣	▣	▣	▣	▣	▣	▣	▣	▣
Room Ambient Temp. °F	▣	▣	▣	▣	▣	▣	▣	▣	▣	▣	▣
Combustion Air Temp. °F	▣	▣	▣	▣	▣	▣	▣	▣	▣	▣	▣
Stack Temperature °F	▣	▣	▣	▣	▣	▣	▣	▣	▣	▣	▣
Stack Draft (InWC)*	▣	▣	▣	▣	▣	▣	▣	▣	▣	▣	▣
Main Flame Signal	▣	▣	▣	▣	▣	▣	▣	▣	▣	▣	▣

** Use only a Slack Tube® Manometer or equivalent. The use of a digital manometer is not recommended.*

OPERATING HISTORY

Boiler Online Hours	▣
Boiler Run Hours	▣
Boiler Cycles	▣
Attempted Ignitions	▣
Successful Ignitions	▣

When complete, please keep this form with the boiler and store a record copy in a safe location. Accurate and complete combustion and maintenance records detailing compliance with the Installation, Operation, and Maintenance Manual must be produced for warranty consideration. Please use photocopies or consult your local Fulton Representative for additional copies of this form.

**No part of this Installation, Operation, and Maintenance manual
may be reproduced in any form or by any means without
permission in writing from Fulton Group N.A., Inc**

Fulton Thermal Corporation is part of Fulton Group N.A., Inc., a global
manufacturer of steam, hot water and thermal fluid heat transfer systems.
Fulton Steam Solutions, Inc. & Fulton Heating Solutions, Inc.
are now Fulton Thermal Corporation.

© Fulton Group N.A., Inc. 2025

