



# ENDURA<sup>®</sup> XE

Condensing Firetube  
Hydronic Boiler

399,000 – 6 Million BTU/HR



- ▶ Up to 15:1 Turndown
- ▶ Flame-by-Wire™ Combustion
- ▶ Real-Time O<sub>2</sub> Compensation™



# HEAVY-HITTER FOR ENERGY SAVINGS

Trusted in hundreds of thousands of installations globally, Fulton boilers are built to last and are renowned for exceptional reliability. ENDURA XE® continues this legacy, combining cutting-edge decarbonization technology with the rugged construction that defines Fulton.

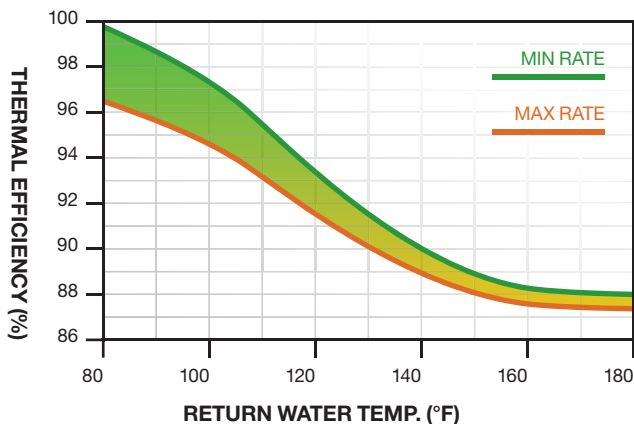

## Reduce Fuel Costs & Emissions

The ultra-high efficiency heat exchanger and fuel-saving burner reduce carbon emissions by 15% and NOx emissions by 80% compared to conventional boilers.

## Simplify Your Installation

Fully electronic combustion controls use Flame-by-Wire™ technology. This installer friendly system is simpler to learn and operate, significantly reducing commissioning time and complexity.

## Trusted Long-Life Durability

Firetube architecture is recognized for superior dependability and ease of installation. ENDURA XE envelops tubes within a large volume of water, eliminating costly buffer tanks and primary-secondary piping.

## LOW MAINTENANCE RELIABLE BURNER

Fulton combines environmentally friendly low NOx emissions with the rugged durability of industrial-grade equipment. Burner maintenance has never been simpler.

- ▶ **Simplified Start-Up & Calibration**
- ▶ **Reduce Energy Costs with Enhanced Heat Transfer**
- ▶ **Enhanced Woven Burner Built for Lasting Reliability**

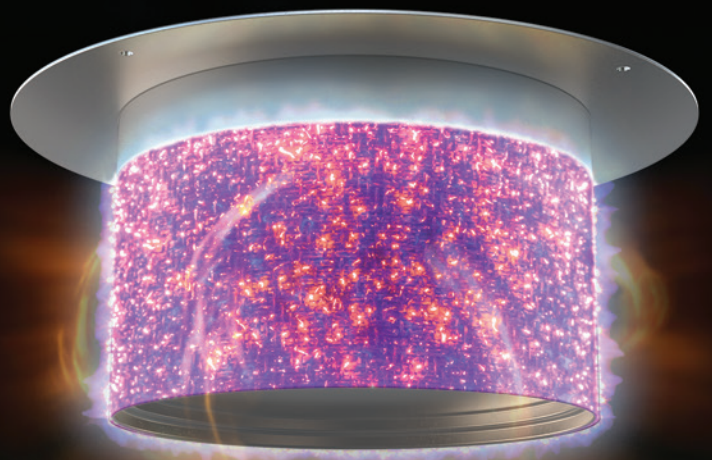

# FIRETUBE TECHNOLOGY

ENDURA XE is engineered and built to the same rugged reliability standards as Fulton's heavy-duty industrial boilers. Superior construction materials and water management make ENDURA XE last longer, even in the most demanding applications.

- ▶ **Industrial-Grade Dependability**
- ▶ **Resilient Against Scale & Corrosion**
- ▶ **Lower Pump Head Requirements**

★ **10 YEAR** ★

HEAT EXCHANGER  
WARRANTY



★ **LIFETIME** ★

THERMAL SHOCK  
WARRANTY



- ▶ **Supercharged Heating**

ENDURA XE packs more performance into a smaller package, keeping your building efficiently and reliably heated while saving valuable space in the mechanical room.

- ▶ **Upgraded Stainless Steel**

Proven 439 and Duplex alloys offer 68 to 160% greater strength than 316L, and are immune to chloride stress corrosion cracking, a catastrophic mode of failure seen with boilers using 304 and 316L.

- ▶ **Long-Lasting Durability**

Innovative water baffle technology prevents scale from forming, ensuring a long-lasting and efficient heat exchanger. This maximizes heating comfort and lowers lifetime fuel costs.



# PURE<sup>®</sup> CONTROL

## Complexity Simplified

Fulton's powerful yet intuitive PURE<sup>®</sup> Control delivers sophisticated capabilities through a user-friendly touchscreen. It efficiently sequences up to 10 boilers and eliminates the need for a master boiler or standalone panel. When a boiler is powered off, the plant seamlessly transitions to the next available stage for reliable heating.

- ▶ Outdoor Reset with Setback Mode
- ▶ Motorized Isolation Valve Control
- ▶ Variable Speed Pump Control
- ▶ Saves Energy by Reducing Cycling
- ▶ Modbus / BACnet Configurable



## FLAME BY WIRE<sup>™</sup>

### Combustion Technology

Inspired by advances in automotive and aviation, Flame-by-Wire<sup>™</sup> technology replaces the use of conventional pneumatics ("neg-reg") and linkages with independent electronic air and gas valves. Real-time O<sub>2</sub> Compensation<sup>™</sup> continuously tunes the burner air-fuel ratio, automatically optimizing for seasonality.

- ▶ Simplifies Start-Up & Maintenance
- ▶ Maximizes Condensing Operation
- ▶ Reduces Fuel Bills & Emissions

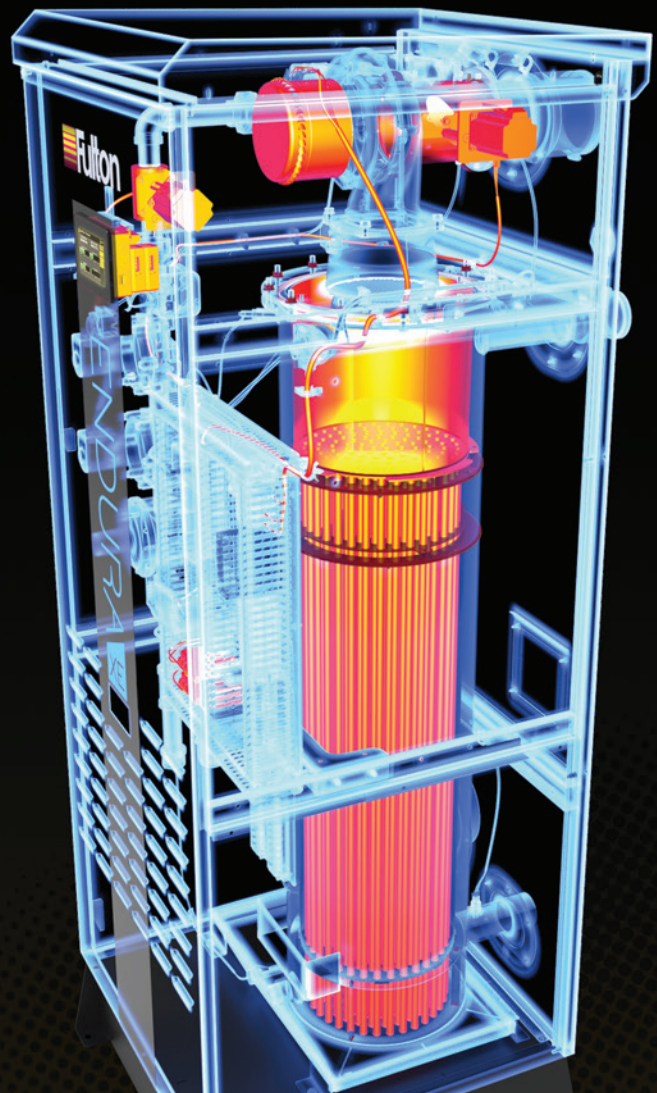

# VARIABLE PRIMARY FLOW DESIGN

Variable primary flow is a simplified piping method that improves temperature comfort, streamlines installation, and eliminates the need for dedicated boiler pumps. Fuel savings are maximized by directing the lowest temperature water straight to the boiler inlet, avoiding inefficient blending in a primary-secondary manifold.

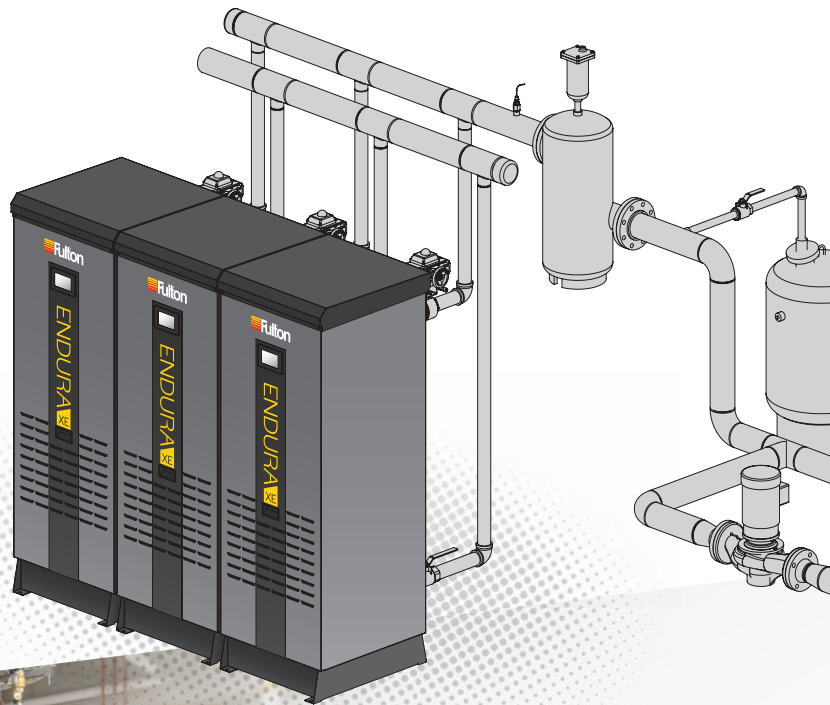

## Compact Design

A compact footprint with zero side clearance makes ENDURA XE an excellent choice for both retrofit and new construction, freeing up valuable mechanical room space.

## Flexible Venting Arrangements

Design supports 16 different venting configurations including sidewall or rooftop, room air or sealed combustion, plastic or stainless flue materials, and manifolded common venting.

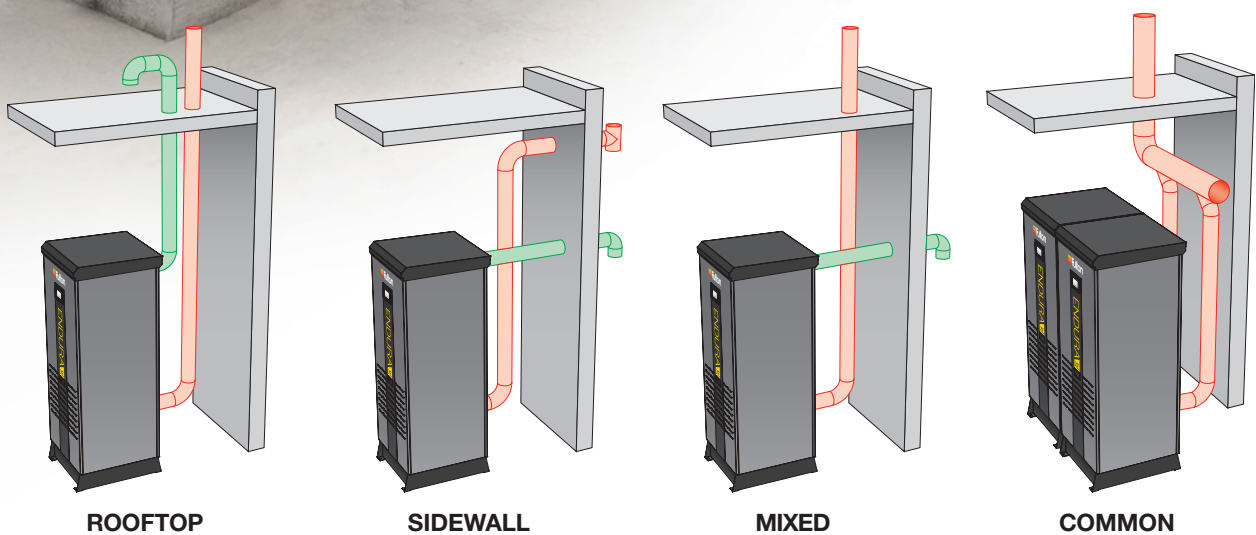

ROOFTOP

SIDEWALL

MIXED

COMMON

# SPECIFICATIONS & DIMENSIONS

MODEL EXE-		399	500	650	750	1000	1500	2000	2500	3000	4000	5000	6000
<b>SPECIFICATIONS</b>													
Input Capacity	MBH	399	500	650	750	1,000	1,500	2,000	2,500	3,000	4,000	5,000	6,000
Water Content	GAL	10.4	10.4	17.9	17.9	24.8	24.8	42.4	54.9	54.9	166	166	166
Pressure Drop at 20°F ΔT	PSI	1.2	2.0	1.4	1.9	1.2	2.8	2.3	1.7	2.5	2.6	4.0	5.8
Operating Weight	LBS	537	537	674	674	1,301	1,325	1,779	2,072	2,072	5,740	5,740	5,740
Electrical Requirements	V/PH	120/1	120/1	120/1	120/1	120/1	120/1	120/1	240/1	240/1	460/3	460/3	460/3
AHRI Thermal Efficiency	%	98.0	97.3	96.3	96.0	97.8	97.6	97.5	97.3	97.2	96.8	96.5	96.2
Turndown Ratio		8:1	10:1	13:1	15:1	15:1	15:1	15:1	15:1	15:1	10:1	13:1	15:1
<b>DIMENSIONS</b>													
(A) Height	IN	73.7	73.7	73.7	73.7	79	79	79.3	79.3	79.3	79	79	79
(B) Width	IN	26.3	26.3	26.3	26.3	29.4	29.4	32.8	32.8	32.8	34	34	34
(C) Base Depth	IN	28.9	28.9	28.9	28.9	36	36	41.8	41.8	41.8	103.5	103.5	103.5
<b>CLEARANCES</b>													
(D) Sides	IN	0	0	0	0	0	0	0	0	0	0 & 24	0 & 24	0 & 24
(E) Front	IN	24	24	24	24	30	30	32	32	32	36	36	36
(F) Top	IN	16	16	16	16	12	12	12	12	12	18	18	18
(G) Rear	IN	12	12	12	12	24	24	24	24	24	36	36	36

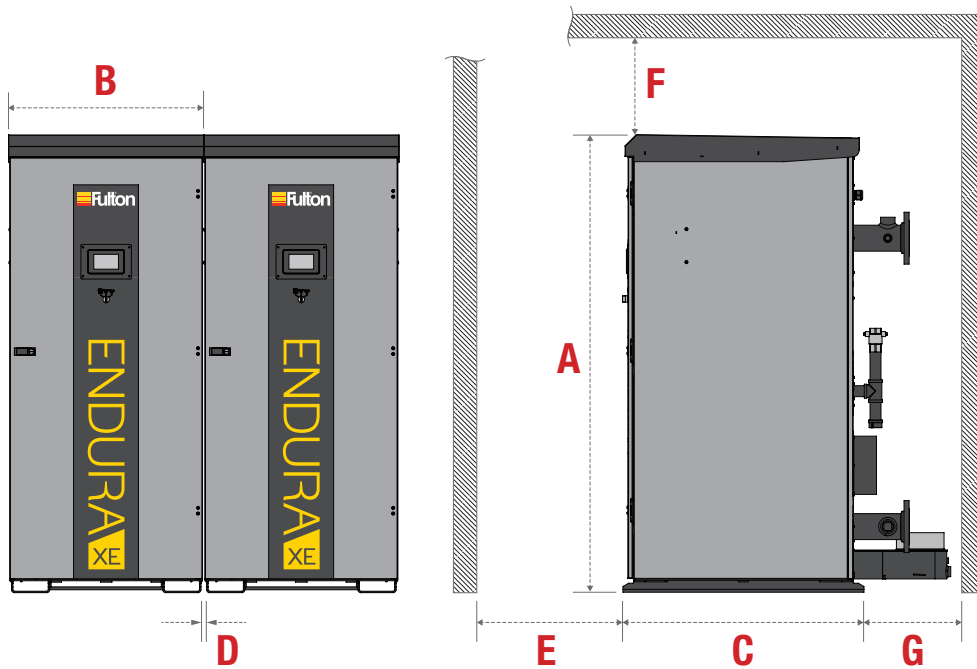

**NOTES:**

- Specifications and dimensions are approximate and for reference only. Fulton practices continuous product improvement and reserves the right to change specifications and/or dimensions without notice.
- Dimensions represent locations from which service clearances are measured, refer to end assembly drawings for overall dimensions.
- \* Compared to DOE minimum requirements



Call: (315) 298-5121

972 Centerville Road  
Pulaski, NY 13142



[fulton.com/enduraxe](http://fulton.com/enduraxe)  
Drawings & documentation available online

ENDURA-XE\_BROCHURE\_251210

